

Belt Maintenance Equipment - Belt Lacing >750kN/m

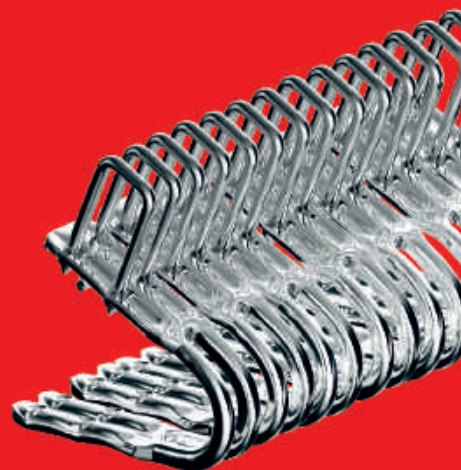

mato

Catalogue 2022-HD

mato



MATO GmbH & Co KG, Main Production Facility and Administration Headquarters, Mühlheim a.M., Deutschland

Table of Contents

Belt Lacing Systems for High Tensile Conveyor Belts



High Performance Fasteners U68, Machine Installed Plate Fasteners and Accessories	4
High Performance Fasteners U30, Machine Installed Plate Fasteners, Stainless Steel Fasteners S30S, Machine Installed Plate Fasteners	5
Eco-Fasteners E30, Machine Installed Plate Fasteners	7
Accessories for Machine Installed Systems U30, S30S, E30	7
Connecting Pins for Systems U68, U30, S30S, E30	13



Stainless Steel Fasteners H60S, H30S, Hammer Installed Plate Fasteners	21
Eco-Fasteners H60E, H30E, Hammer Installed Plate Fasteners	23
Accessories for Hammer Installed Systems H60, H30, MR30	24
Eco-Fasteners MR30, Hammer Installed Plate Fasteners	26
Connecting Pins for Systems H60, H30, MR30	27



Bold Plate Fasteners MS, Screw Installed Fasteners	31
Tools and Templates for Bolt Plate fasteners MS	33
Repair Fasteners S80, Hammer Installed Fastener	35
MATO BOND - Belt repair, 2 component PU Systems	36



Belt Clamp 60 kN	38
Belt Clamp 30 kN	38
T-Square	38
Belt Cutter TMG, T and Accessories	39
Belt Cutter HD, Spare Blades for Belt Cutter	39

1,2,3.. §... Abc.....§....	Order No. Index, Terms & Conditions, General Remarks	40
----------------------------	--	----

Please note: pictures may differ from original product

mato



Selection Chart

for Machine Installed Plate Fasteners

Fasteners **U68 and U68A** are another step-up compared to our U30 Fasteners. Additionally, Fasteners U68 and U68A have a deeper reachback and higher plate thickness, for more safety and wear resistance. The outstanding features of both types are:



The **S30S-System** is used in applications where higher corrosion is a problem. In comparison to U30, the S30S has stainless steel staples with press fit specialised to the material combinations.

The **E30-System** is used in applications with regular and short runtime. In comparison to U30, the E30 has special steel staples and carbon steel plates. The press fit of the staples is specialised to the material combinations.

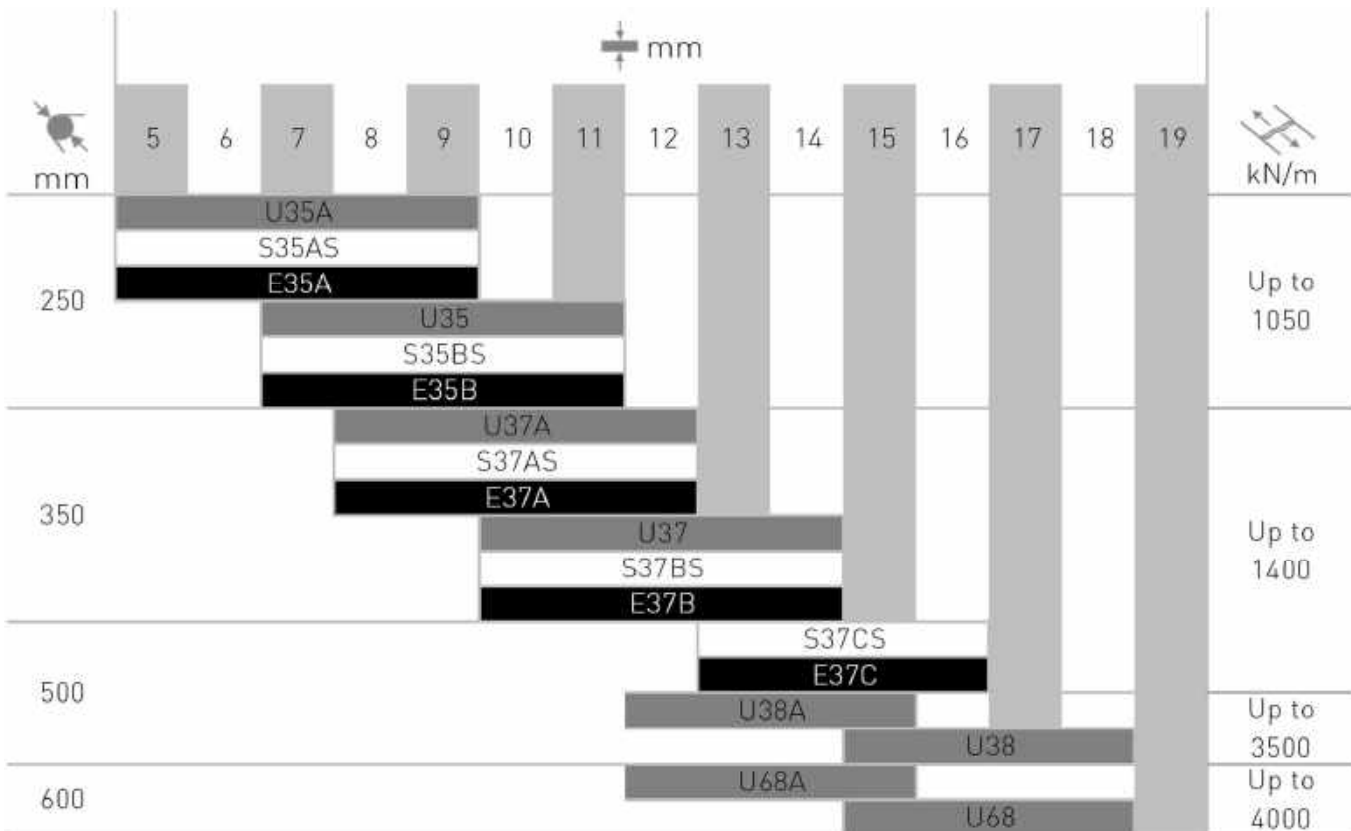

Material combinations:

Plate	Staple
Cr (S) Steel	Spring Steel
Cr (S) Steel	CrNi (SS) Steel
Carbon	Special Steel

Thicker belts can be skived (covers) to fit

Belt Width	Belt Thickness	Order No.	kg
Belt Fastener U68A - Standard			
Belt Strength up to 4000 kN/m		Minimum Pulley Diameter 600mm	
up to 1000 mm	12-15mm	41 168 15 00	4.8
up to 1200mm	12-15mm	41 168 15 12	5.6
up to 1400 mm	12-15mm	41 168 15 14	6.5
Belt Fastener U68 - Standard			
Belt Strength up to 4000 kN/m		Minimum Pulley Diameter 600mm	
up to 1000mm	15-18mm	41 168 14 44	4.8
up to 1200mm	15-18mm	41 168 14 45	5.6
up to 1400mm	15-18mm	41 168 14 46	6.5



- High compression into the belt
- Press fit of staples
- Staple guard
- Cold forged plate with loops for highest strengths
- High wear resistant plate material (chromium steel)
- High tensile spring steel staples

Staple Material: **Spring Steel**
Plate Material: **Stainless Chromium Steel**

Pricing: based on boxes with Fastener Strips of 200mm length, (can be shortened individually). Content is sufficient for one complete lace of according belt width (without Connecting Pin)

Accessories

for Machine Installed System U68 (limited use with systems U30, S30S, E30)

Belt Width	Order No.	kg	
Screw Clamping Frame SS 68 (Stainless Steel)			
up to 1200mm	41 129 44 17	33.6	For use with Lacers LM 35-68 and YMD-2SI as well as Machine Skivers XTV . For installation of Fastener series U68A / U68 Picture see page 7
up to 1400mm	41 129 44 18	36.2	
up to 1600mm	41 129 44 19	40.0	
Screw Clamping Frame MF 68 (Stainless Steel)			
up to 1200mm	42 160 20 13	39.6	For use with Lacers LM 35-68 and YMD-2SI as well as Machine Skivers XTV / XTV-BS. For installation of Fastener series U68A / U68. Speed up the installation process and minimizes errors. Picture see page 8
up to 1400mm	42 160 20 12	43.3	
up to 1600mm	42 160 20 11	47.4	
Lacers with manual transport			
Pneumatic Lacer LM35-68	41 130 40 12	24.0	For use with Frames SS-68 and MF-68. Pneumatic Lacer LM 35-68 installs all Fasteners of the series U68 / U68A. Driven by compressed air 4-8 bar Picture see page 8
Hydraulic Lacer YMD-2SI	41 304 44 50	21.7	For use with Frames SS-68 and MF-68. Hydraulic Lacer YMD-2SI installs all Fasteners of series U68 / U68A. Driven by hydraulic power, pressure range 120 - 160 bar / 8l/min. Picture see page 8
Machine Skiver U68			
Machine Skiver XTV-BS Skiving on both sides	42 124 00 07	6.9	Reduction of cover thickness of conveyor belts. For use with Frames MF and SS. Belt thickness 7-31mm. Skiving on both sides together with Frame MF only. Blade XTV can be adjusted to skiving depth, enables cleaner friendly skiving. Crank Drive. Picture see page 10
Machine Skiver XTV Skiving on one side	42 124 00 10	6.9	

Accessories and Connecting Pins see pages 7 - 19.

Belt Width	Belt Thickness	Order No.	kg
Belt Fastener U35A - Standard			
Belt Strength up to 1050 kN/m		Minimum Pulley Diameter 250 mm	
up to 1000 mm	5 - 9 mm	41 114 14 29	2.6
up to 1200 mm	5 - 9 mm	41 114 14 30	3.1
up to 1400 mm	5 - 9 mm	41 114 14 31	3.6
Belt Fastener U35 - Standard			
Belt Strength up to 1050 kN/m		Minimum Pulley Diameter 250 mm	
up to 1000 mm	7 - 11 mm	41 114 07 16	2.7
up to 1200 mm	7 - 11 mm	41 114 07 12	3.2
up to 1400 mm	7 - 11 mm	41 114 07 10	3.7
Belt Fastener U37A - Standard			
Belt Strength up to 1400 kN/m		Minimum Pulley Diameter 350 mm	
up to 1000 mm	8 - 12 mm	41 114 15 54	3.2
up to 1200 mm	8 - 12 mm	41 114 08 12	3.8
up to 1400 mm	8 - 12 mm	41 114 08 16	4.5
Belt Fastener U37 - Standard			
Belt Strength up to 1400 kN/m		Minimum Pulley Diameter 350 mm	
up to 1000 mm	10 - 14 mm	41 114 00 18	3.2
up to 1200 mm	10 - 14 mm	41 114 00 15	
up to 1400 mm	10 - 14 mm	41 114 00 12	4.5
Belt Fastener U38A - Standard			
Belt Strength up to 3500 kN/m		Minimum Pulley Diameter 500 mm	
up to 1000 mm	12 - 15 mm	41 114 15 21	4.2
up to 1200 mm	12 - 15 mm	41 114 14 22	5.0
up to 1400 mm	12 - 15 mm	41 114 14 14	5.8
Belt Fastener U38 - Standard			
Belt Strength up to 3500 kN/m		Minimum Pulley Diameter 500 mm	
up to 1000 mm	15 - 18 mm	41 114 14 16	4.2
up to 1200 mm	15 - 18 mm	41 114 14 19	5.0
up to 1400 mm	15 - 18 mm	41 114 17 82	5.9
Belt Fastener U35A+ - Sealed			
Belt Strength up to 1050 kN/m		Minimum Pulley Diameter 250 mm	
up to 1000 mm	5 - 9 mm	41 114 15 47	2.7
up to 1200 mm	5 - 9 mm	41 114 07 35	3.2
up to 1400 mm	5 - 9 mm	41 114 07 09	3.8
Belt Fastener U35+ - Sealed			
Belt Strength up to 1050 kN/m		Minimum Pulley Diameter 250 mm	
up to 1000 mm	7 - 11 mm	41 114 07 17	2.8
up to 1200 mm	7 - 11 mm	41 114 07 18	3.3
up to 1400 mm	7 - 11 mm	41 114 07 08	3.9
Belt Fastener U37A+ - Sealed			
Belt Strength up to 1400 kN/m		Minimum Pulley Diameter 350 mm	
up to 1000 mm	8 - 12 mm	41 114 15 55	3.3
up to 1200 mm	8 - 12 mm	41 114 15 56	4.0
up to 1400 mm	8 - 12 mm	41 114 15 59	4.6
Belt Fastener U37+ - Sealed			
Belt Strength up to 1400 kN/m		Minimum Pulley Diameter 350 mm	
up to 1000 mm	10 - 14 mm	41 114 00 21	3.4
up to 1200 mm	10 - 14 mm	41 114 00 22	4.0
up to 1400 mm	10 - 14 mm	41 114 00 24	4.7
Belt Fastener U38A+ - Sealed			
Belt Strength up to 3500 kN/m		Minimum Pulley Diameter 500 mm	
up to 1000 mm	12 - 15 mm	41 114 15 22	4.3
up to 1200 mm	12 - 15 mm	41 114 14 18	5.2
up to 1400 mm	12 - 15 mm	41 114 14 15	6.1
Belt Fastener U38+ - Sealed			
Belt Strength up to 3500 kN/m		Minimum Pulley Diameter 500 mm	
up to 1000 mm	15 - 18 mm	41 114 15 27	4.3
up to 1200 mm	15 - 18 mm	41 114 14 23	5.2
up to 1400 mm	15 - 18 mm	41 114 14 95	6.2



- High compression into the belt
- Press fit of staples
- Staple guard
- Cold forged plate with loops for highest strengths
- High wear resistant plate material (chromium steel)
- High tensile spring steel staples

Staple Material: **Spring Steel**

Plate Material: **Stainless Chromium Steel**

Pricing: based on boxes with Fastener Strips of 200mm length, (can be shortened individually). Content is sufficient for one complete lace of according belt width (without Connecting Pin)



- Polyurethan Sealing prevents spillage of the material and increases lifetime of the Connecting Pin by a grease filling

Staple Material: **Spring Steel**

Plate Material: **Stainless Chromium Steel**

Pricing: based on boxes with Fastener Strips of 200mm length, (can be shortened individually). Content is sufficient for one complete lace of according belt width (without Connecting Pin)

Belt Width	Belt Thickness	Order No.	kg
------------	----------------	-----------	----

Belt Fastener S35AS - Standard

Belt Strength up to 1050 kN/m		Minimum Pulley Diameter 250 mm	
up to 1000 mm	5 - 9 mm	41 114 07 68	2.6
up to 1200 mm	5 - 9 mm	41 114 07 50	3.1
up to 1400 mm	5 - 9 mm	41 114 07 44	3.6

Belt Fastener S35BS - Standard

Belt Strength up to 1050 kN/m		Minimum Pulley Diameter 250 mm	
up to 1000 mm	7 - 11 mm	41 114 07 73	2.7
up to 1200 mm	7 - 11 mm	41 114 07 42	3.2
up to 1400 mm	7 - 11 mm	41 114 07 45	3.7

Belt Fastener S37AS - Standard

Belt Strength up to 1400 kN/m		Minimum Pulley Diameter 350 mm	
up to 1000 mm	8 - 12 mm	41 114 07 56	3.2
up to 1200 mm	8 - 12 mm	41 114 07 48	3.8
up to 1400 mm	8 - 12 mm	41 114 07 46	4.5

Belt Fastener S37BS - Standard

Belt Strength up to 1400 kN/m		Minimum Pulley Diameter 350 mm	
up to 1000 mm	10 - 14 mm	41 114 07 61	3.2
up to 1200 mm	10 - 14 mm	41 114 07 43	4.5
up to 1400 mm	10 - 14 mm	41 114 07 47	4.5

Belt Fastener S37CS - Standard

Belt Strength up to 1400 kN/m		Minimum Pulley Diameter 500 mm	
up to 1000 mm	13 - 16 mm	41 114 07 80	3.4
up to 1200 mm	13 - 16 mm	41 114 07 81	4.1
up to 1400 mm	13 - 16 mm	41 114 07 64	4.8



- High compression into the belt
- Staple guard
- Cold forged plate with loops for highest strengths
- High wear resistant plate material (chromium steel)
- Stainless Steel Staples

Staple Material: **Stainless Steel**
Plate Material: **Stainless Chromium Steel**

Pricing: based on boxes with Fastener Strips of 200mm length, (can be shortened individually). Content is sufficient for one complete lace of according belt width (without Connecting Pin)

Belt Fastener S35AS+ - Sealed

Belt Strength up to 1050 kN/m		Minimum Pulley Diameter 250 mm	
up to 1000 mm	5 - 9 mm	41 114 07 69	2.7
up to 1200 mm	5 - 9 mm	41 114 07 70	3.2
up to 1400 mm	5 - 9 mm	41 114 07 85	3.7

Belt Fastener S35BS+ - Sealed

Belt Strength up to 1050 kN/m		Minimum Pulley Diameter 250 mm	
up to 1000 mm	7 - 11 mm	41 114 07 74	2.8
up to 1200 mm	7 - 11 mm	41 114 07 75	3.3
up to 1400 mm	7 - 11 mm	41 114 07 66	3.9

Belt Fastener S37AS+ - Sealed

Belt Strength up to 1400 kN/m		Minimum Pulley Diameter 350 mm	
up to 1000 mm	8 - 12 mm	41 114 07 57	3.3
up to 1200 mm	8 - 12 mm	41 114 07 58	4.0
up to 1400 mm	8 - 12 mm	41 114 07 67	4.6

Belt Fastener S37BS+ - Sealed

Belt Strength up to 1400 kN/m		Minimum Pulley Diameter 350 mm	
up to 1000 mm	10 - 14 mm	41 114 07 62	3.4
up to 1200 mm	10 - 14 mm	41 114 07 63	4.0
up to 1400 mm	10 - 14 mm	41 114 07 83	4.7

Belt Fastener S37CS+ - Sealed

Belt Strength up to 1400 kN/m		Minimum Pulley Diameter 500 mm	
up to 1000 mm	13 - 16 mm	41 114 17 48	3.6
up to 1200 mm	13 - 16 mm	41 114 17 49	4.3
up to 1400 mm	13 - 16 mm	41 114 07 84	5.0



- Polyurethan Sealing prevents spillage of the material and increases lifetime of the Connecting Pin by a grease filling

Staple Material: **Stainless Steel**
Plate Material: **Stainless Chromium Steel**

Pricing: based on boxes with Fastener Strips of 200mm length, (can be shortened individually). Content is sufficient for one complete lace of according belt width (without Connecting Pin)

Belt Width	Belt Thickness	Order No.	kg
Belt Fastener E35A - Standard			
Belt Strength up to 1050 kN/m		Minimum Pulley Diameter 250 mm	
up to 1000 mm	5 - 9 mm	41 114 07 38	2.6
up to 1200 mm	5 - 9 mm	41 114 07 51	3.1
up to 1400 mm	5 - 9 mm	41 114 92 01	3.6
Belt Fastener E35B - Standard			
Belt Strength up to 1050 kN/m		Minimum Pulley Diameter 250 mm	
up to 1000 mm	7 - 11 mm	41 114 07 39	2.7
up to 1200 mm	7 - 11 mm	41 114 07 40	3.2
up to 1400 mm	7 - 11 mm	41 114 92 02	3.7
Belt Fastener E37A - Standard			
Belt Strength up to 1400 kN/m		Minimum Pulley Diameter 350 mm	
up to 1000 mm	8 - 12 mm	41 114 07 54	3.2
up to 1200 mm	8 - 12 mm	41 114 07 49	3.8
up to 1400 mm	8 - 12 mm	41 114 92 03	4.4
Belt Fastener E37B - Standard			
Belt Strength up to 1400 kN/m		Minimum Pulley Diameter 350 mm	
up to 1000 mm	10 - 14 mm	41 114 07 59	3.2
up to 1200 mm	10 - 14 mm	41 114 07 41	3.6
up to 1400 mm	10 - 14 mm	41 114 92 04	4.5
Belt Fastener E37C - Standard			
Belt Strength up to 1400 kN/m		Minimum Pulley Diameter 500 mm	
up to 1000 mm	13 - 16 mm	41 114 07 76	3.4
up to 1200 mm	13 - 16 mm	41 114 07 77	4.1
up to 1400 mm	13 - 16 mm	41 114 92 05	4.7



- Light compression into the belt
- Staple guard
- Cold forged plate with loops
- High wear resistant plate material
- High tensile special steel staples

Staple Material: **Special Steel**
Plate Material: **Carbon Steel**

Pricing: based on boxes with Fastener Strips of 200mm length, (can be shortened individually). Content is sufficient for one complete lace of according belt width (without Connecting Pin)

Accessories

for Machine Installed Systems U30, S30S, E30

Belt Width	Order No.	kg
Screw Clamping Frame S		
For use with Lacers HM, LM and YMD-2SI as well as Skivers S, HD and XTV. For installation of Fastener series U30, S30S and E30		
up to 1000 mm	41 129 43 01	28.5
up to 1200 mm	41 129 44 01	32.5
up to 1400 mm	41 129 46 01	36.1
up to 1600 mm	41 129 47 01	40.0
up to 1800 mm	41 129 48 02	44.0
up to 2000 mm	41 129 58 01	50.0
Screw Clamping Frame SS (Stainless Steel)		
For use with Lacers HM, LM and YMD-2SI as well as Skivers S, HD and XTV. For installation of Fastener series U30, S30S and E30		
up to 1000 mm	41 129 44 05	29.6
up to 1200 mm	41 129 44 07	33.6
up to 1400 mm	41 129 44 08	36.2
up to 1600 mm	41 129 44 09	40.0
up to 1800 mm	41 129 44 10	44.0
up to 2000 mm	41 129 44 11	50.0

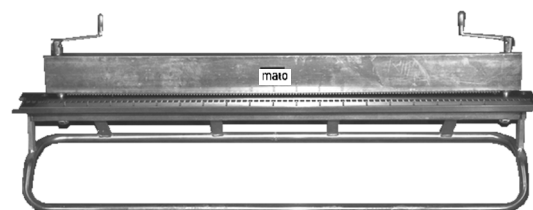

Accessories and Connecting Pins see pages 7 - 19.

Belt Width	Order No.	kg
Screw Clamping Frame MF (Stainless Steel - makes belt handling easier)		
For use with Lacers HM, LM, and YMD-2SI as well as Belt Skivers S, HD, XTV / XTV-BS. For installation of Fastener series U30, S30S, and E30. Quickens the installation process and minimizes errors		
up to 1200 mm	42 160 20 03	39.6
up to 1400 mm	42 160 20 02	43.3
up to 1600 mm	42 160 20 01	47.4
up to 1800 mm	42 160 20 04	51.7
up to 2000 mm	42 160 20 00	59.0

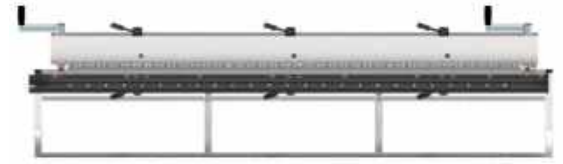

Lacers with manual transport

Manual Lacer HM 35-38 41 129 40 02 15.8

For use with Frames S, SS and MF. The Manual Lacer HM 35-38 installs all Fasteners of the series U30, S30S, E30. Driven by manual force



Pneumatic Lacer LM 35-38 41 129 40 30 24.0

For use with Frames S, SS and MF. The Pneumatic Lacer LM 35-38 installs all Fasteners of the series U30, S30S, E30. Driven by compressed air 4-8bar



Hydraulic Lacer YM-D2SI 35-68 41 304 44 50 21.7

For use with Frames S, SS and MF. The Hydraulic Lacer YM-D2SI 35-68 installs all Fasteners of the series U30, U68, S30S, E30. Driven by hydraulic power. Pressure range 120-160 bar / 8l/min. Incl. Storage case, see page 9



Description	Order No.	kg
-------------	-----------	----

Storage Case

Solid sheet metal Storage Case - it will ensure safe transport and storage of the Lacer YM-D2S. It comes with a hinged cover and 2 swivelling handles. Measurements inside 470 x 248 x 348 mm (LxWxH)

Storage Case YM-D2S 470 x 248 x 348 mm (LxWxH)	41 304 44 01	9.8
--	---------------------	------------



Hydraulic Power Pack for Lacer YM-D2S 35-68

Compact-Hydraulic Power Pack specially aligned for use with the Lacer YM-D2S 35-68. Dual-circuit Power Pack with 120/140 bar, available in different electrical types. Suitable for continuous use with Lacer YM-D2S 35-68.

Compact-Hydraulic Power Pack YM-D2S 400V/50Hz/3Phases	41 304 44 12	27.7
Compact-Hydraulic Power Pack YM-D2S 110V/60Hz/1Phase	41 304 44 13	34.8
Compact-Hydraulic Power Pack YM-D2S 220V/60Hz/1Phase	41 304 44 14	34.4



Belt Thickness	Order No.	kg
----------------	-----------	----

Machine Skiver S

In order to reduce top cover thickness of conveyor belts. To use with Frames S, SS and MF. Belt thickness range 5-20mm. Crank Drive.

Machine Skiver S 5-20 mm	42 123 00 04	6.9
-----------------------------	--------------	-----

Skiver Blade S for Machine Skiver



Skiver Blade S	42 123 00 06	0.1
----------------	--------------	-----

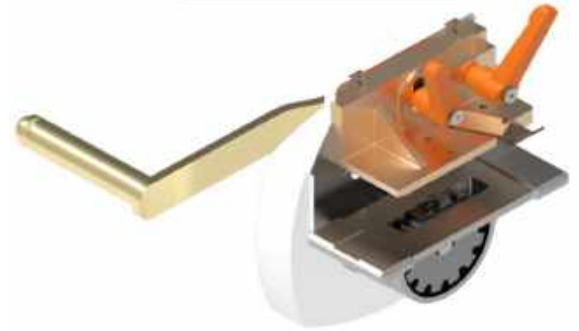

Machine Skiver HD

In order to reduce top cover thickness of conveyor belts. To use with Frames S, SS and MF. Belt thickness range 15-30mm. Crank Drive.

Machine Skiver HD 15-30 mm	42 124 00 04	6.9
-------------------------------	--------------	-----

Skiver Blade HD for Machine Skiver



Skiver Blade HD	42 123 02 00	0.1
-----------------	--------------	-----

Machine Skiver XTV-BS

In order to reduce top cover thickness of conveyor belts. To use with Frames S, SS, and MF. Belt thickness range 7-31mm. Skiving on both sides at once only possible with Frame MF. Skiver Blade XTV can be adjusted to the skiving depth, it enables cleaner friendly skiving. Crank Drive.

Machine Skiver XTV-BS 7-31 mm	42 124 00 07	7.1
----------------------------------	--------------	-----

Machine Skiver XTV Skiving on one side	42 124 00 10	6.9
---	--------------	-----



Skiver Blade XTV	42 123 01 14	0.1
------------------	--------------	-----

Skiver Blade XTV



Skiver Blade BS	42 123 01 12	0.1
-----------------	--------------	-----

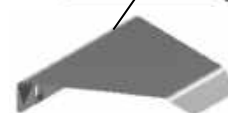

Skiver Blade BS

Description Order No. kg

Wave Master Systems WSS and Optimat

In order to minimize wave and bowing when installing machine fasteners

Wave Master Kit (Metal Box) V2 41 129 58 22 3.8
 (Clamping Unit with Quick Clamping Device, 20 Tension Ropes with one end, safety ferrule (2600 mm), Pincer and Distance Holder)



WSS-Installation Unit 43 121 34 40 0.7
 (PU= 10 pieces)
 consists of Clamping Unit and Clamping Piece



Tension Ropes with one end safety ferrule 43 121 34 36 0.8
 (PU= 20 pieces)
 L=1800 mm
 for WSS Installation Unit



Tension Ropes with one end safety ferrule 43 121 34 56 1.1
 (PU= 20 pieces)
 L=2600 mm
 for WSS Installation Unit



Optimat Installation Unit 43 122 10 20
 (Measuring and Tensioning Block)
 In order to minimize wave and bowing when installing machine fasteners in high belt strengths



Optimat Pincer 43 122 10 14 0.4
 For cutting Optimat Tension Ropes

Optimat Tension Ropes with two end safety ferrule 43 122 10 15 0.2
 Width 1000
 (PU = 2 pieces)

Optimat Tension Ropes with two end safety ferrule 43 122 10 04 0.2
 Width 1200
 (PU = 2 pieces)

Optimat Tension Ropes with two end safety ferrule 43 122 10 05 0.3
 Width 1400
 (PU = 2 pieces)



Setting Gauge for Lacers and Skivers

Setting Gauge for Lacers and Skivers 43 122 10 10 0.3
 Setting Gauge for all types of Lacers and Machine Skivers S and HD



Description	Order No.	kg
-------------	-----------	----

Mark and Cut

Belt Marker BT-1 38 559 70 0.1
 Belt Marker permanently marks conveyor belts. Marking depth approx. 0.8 mm, width approx. 2.0 mm



Clamping Collar - P1 42 130 00 01 0.1
 Inside diameter 6mm

Clamping Collar - P2 42 130 00 02 0.1
 Inside diameter 7mm

Clamping Collar - P3 42 130 00 03 0.1
 Inside diameter 8mm



Clamping Collars are used to stop pin migration on low tensile applications. Available sizes for P1, P2, P3

Installation Tools for Connecting Pins

Hammer Pin Driver 42 123 00 27 1.1
 for Plain Connecting Pins



Inserting Tool 42 123 00 03 1.4
 for Screw Connecting Pins



Inserting Tool SS1 43 123 00 03 1.2
 with keyless chuck (not illustrated) for Screw Connecting Pins

Insert Ratchet Eco 42 123 00 07 0.9
 for Screw Connecting Pins
 Inexpensive type for installing Screw Connecting Pins by ratch



Screw Pin Inserting Tool SS2 42 123 03 00 3.3
 for Screw Connecting Pins
 Both-sided quick chuck for counter-clockwise and clockwise rotation. Working pressure 4 - 6 bar



Belt Skiving

Power Tool (230V/50Hz) 42 160 10 20 1.8
 for Skiving Blades below



flsBlade p H30/60-2 42 160 10 02 0.1
 2 mm Skiving Depth not adjustable

flsBlade p H30/60-3 42 160 10 03 0.1
 3 mm Skiving Depth not adjustable

flsBlade p H30/60-4 42 160 10 04 0.1
 4 mm Skiving Depth not adjustable



Blade for Power Tool

Selection Chart

Connecting Pins for Plate Fasteners

MATO Connecting Pins are aligned in design and material composition to MATO Fasteners. Choosing the right Connecting Pin is important for reaching the optimum performance of the splice in your application.

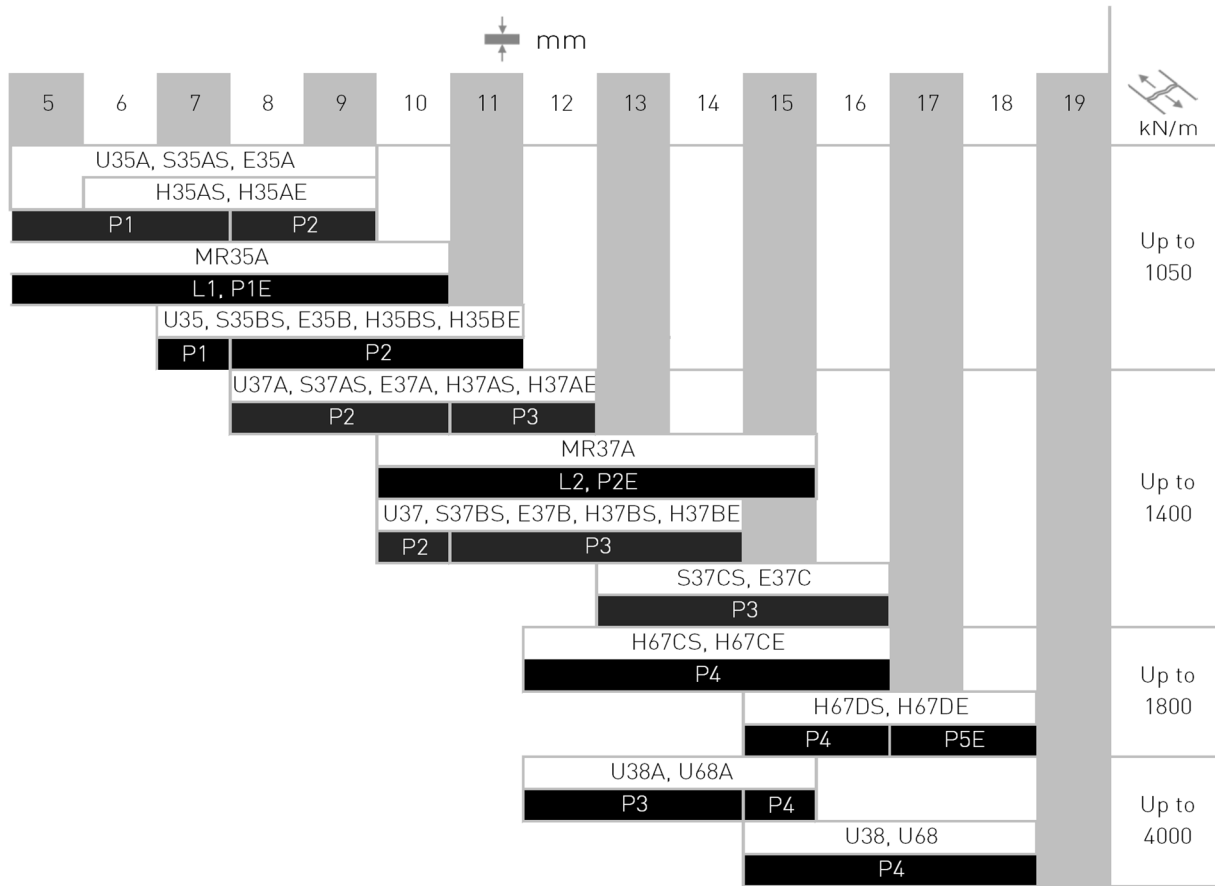

Connecting Pins	High Tension Application	Troughing	No Troughing	Rust Resistant	Chemical Resistant	Wear Properties	Magnetic
L...	●●●○○	●●●○○	●●●○○	●●●○○	○○○○○	●●○○○	heavy
P...E	●●●●○	●●●●○	●●●●●	●●○○○	○○○○○	●●●○○	yes
P...S	●●●●○	●●●●○	●●●●●	●●●●○	●●○○○	●●●○○	yes
P...C	●●●●○	●●●●○	●●●●●	●●●●●	●●●●○	●●●●○	slightly
P...K	●●●●●	●●●●○	●●●●●	●●○○○	○○○○○	●●●●●	yes

poor ○○○○○ excellent ●●●●●

L... - Design

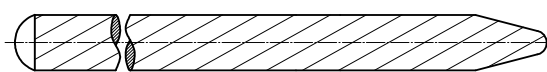

P... - Design

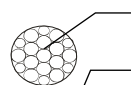

High Tensile Galvanized Cable

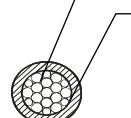

High Tensile Stainless Chromium-Nickel Cable

- P...E - Special Steel
- P...S - Stainless Chromium Steel
- P...C - Stainless Chromium-Nickel Steel
- P...K - High Wear Resistant Steel

Length	Order No.	kg
Connecting Pins P1K		
Min. Diameter 5,3 mm		
635 mm	42 140 06 35	0.1
735 mm	42 140 07 35	0.1
785 mm	42 139 20 17	0.1
885 mm	42 140 08 85	0.2
985 mm	42 139 20 18	0.2
1035 mm	42 140 10 35	0.2
1185 mm	42 139 20 19	0.2
1335 mm	42 140 13 35	0.2
1385 mm	42 139 20 20	0.2
1585 mm	42 140 15 85	0.3
Connecting Pins P2K		
Min. Diameter 6,4 mm		
635 mm	42 131 06 35	0.2
735 mm	42 131 07 35	0.2
785 mm	42 131 08 00	0.2
885 mm	42 131 08 85	0.2
985 mm	42 131 10 00	0.2
1035 mm	42 131 10 50	0.3
1185 mm	42 131 12 00	0.3
1335 mm	42 131 13 35	0.3
1385 mm	42 131 14 00	0.4
1585 mm	42 131 15 85	0.4
1785 mm	42 131 17 85	0.4
Connecting Pins P3K		
Min. Diameter 7,1 mm		
785 mm	42 139 20 25	0.2
885 mm	42 139 08 85	0.3
985 mm	42 129 25 81	0.3
1035 mm	42 139 10 35	0.3
1185 mm	42 129 25 84	0.3
1335 mm	42 139 13 35	0.4
1385 mm	42 129 25 87	0.4
1585 mm	42 129 26 04	0.5
1785 mm	42 129 29 12	0.5
Connecting Pins P4K		
Min. Diameter 8,9 mm		
785 mm	42 133 08 00	0.4
885 mm	42 133 08 85	0.4
985 mm	42 133 10 00	0.4
1035 mm	42 133 10 35	0.5
1185 mm	42 133 12 00	0.5
1335 mm	42 133 13 35	0.6
1385 mm	42 133 14 00	0.6
1585 mm	42 129 29 09	0.7
1785 mm	42 133 19 17	0.8
1985 mm	42 133 19 85	0.9



High Tensile
Stainless
Chromium-Nickel
Steel

High Wear
Resistant Steel

Highest wear resistance

Excellent for
- high belt tension

very good for
- trough / no trough

Connecting Pins

With Threaded Ends for Systems U68, U30, S30S, E30

Length	Order No.	kg
Connecting Pins P1KG		
Min. Diameter 5.3 mm		
650 mm	42 129 20 75	0.1
750 mm	42 129 20 73	0.1
800 mm	42 139 20 21	0.1
900 mm	42 139 09 00	0.2
1000 mm	42 139 20 22	0.2
1050 mm	42 139 10 50	0.2
1200 mm	42 139 20 23	0.2
1350 mm	42 139 13 50	0.2
1400 mm	42 139 20 24	0.2
1600 mm	42 139 16 00	0.3
Connecting Pins P2KG		
Min. Diameter 6.4 mm		
650 mm	42 132 06 50	0.2
750 mm	42 132 07 50	0.2
800 mm	42 132 08 00	0.2
900 mm	42 132 09 00	0.2
1000 mm	42 132 10 00	0.3
1050 mm	42 132 10 50	0.3
1200 mm	42 132 12 00	0.3
1350 mm	42 132 13 50	0.3
1400 mm	42 132 14 00	0.4
1600 mm	42 132 16 00	0.4
1800 mm	42 132 18 00	0.4
Connecting Pins P3KG		
Min. Diameter 7.1 mm		
800 mm	42 139 20 26	0.2
900 mm	42 129 25 39	0.3
1000 mm	42 129 25 82	0.3
1050 mm	42 129 26 05	0.3
1200 mm	42 129 25 85	0.3
1350 mm	42 129 26 06	0.4
1400 mm	42 129 25 88	0.4
1600 mm	42 129 26 03	0.5
1800 mm	42 129 26 10	0.5
Connecting Pins P4KG		
Min. Diameter 8.9 mm		
800 mm	42 134 08 00	0.4
900 mm	42 134 09 00	0.4
1000 mm	42 134 10 00	0.4
1050 mm	42 134 10 50	0.5
1200 mm	42 134 12 00	0.5
1350 mm	42 134 13 50	0.6
1400 mm	42 134 14 00	0.6
1600 mm	42 134 16 00	0.7
1800 mm	42 134 18 00	0.8
2000 mm	42 134 20 00	0.9



Recommended for Sealed Fasteners.
Easy installation,
Installation Tools required
(page 12)

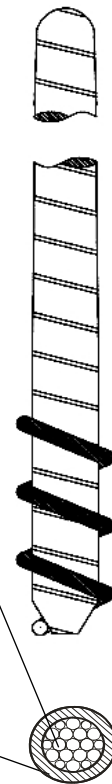

High Tensile
Stainless
Chromium-Nickel
Steel

High Wear
Resistant Steel

Highest wear resistance

Excellent for
- high belt tension

very good for
- trough / no trough

Length	Order No.	kg	
Connecting Pins P1C Min. Diameter 5.3 mm			
635 mm	42 127 00 40	0.3	
735 mm	42 127 01 59	0.1	
785 mm	42 127 01 35	0.1	
885 mm	42 127 00 32	0.2	
985 mm	42 127 01 30	0.2	
1035 mm	42 127 01 33	0.2	
1185 mm	42 127 01 34	0.2	
1335 mm	42 127 00 41	0.2	
1385 mm	42 127 00 37	0.2	
1585 mm	42 127 00 38	0.3	
Connecting Pins P2C Min. Diameter 6.4 mm			
635 mm	42 128 00 19	0.2	<p>High Tensile Stainless Chromium-Nickel Steel</p> <p>Stainless Chromium-Nickel</p>
735 mm	42 128 00 16	0.2	
785 mm	42 128 00 13	0.2	
885 mm	42 128 00 06	0.2	
985 mm	42 128 09 86	0.3	
1035 mm	42 128 00 04	0.3	
1185 mm	42 128 00 02	0.3	
1335 mm	42 128 00 08	0.3	
1385 mm	42 128 00 12	0.4	
1585 mm	42 128 00 03	0.4	
Connecting Pins P3C Min. Diameter 7.1 mm			
785 mm	42 129 24 92	0.2	<p>Very high wear resistance</p> <p>Highest level of corrosion resistance as well as very good chemical resistance</p> <p>Very good for - high belt tension - trough / no trough</p> <p>slightly magnetic</p>
885 mm	42 129 24 81	0.3	
985 mm	42 129 24 99	0.3	
1035 mm	42 129 24 82	0.3	
1185 mm	42 129 27 42	0.3	
1335 mm	42 129 24 83	0.4	
1385 mm	42 129 24 93	0.4	
1585 mm	42 129 24 95	0.5	
Connecting Pins P4C Min. Diameter 8.5 mm			
785 mm	42 129 25 96	0.3	
885 mm	42 129 25 93	0.4	
985 mm	42 129 25 48	0.4	
1035 mm	42 129 25 94	0.4	
1185 mm	42 129 25 49	0.5	
1335 mm	42 129 25 67	0.5	
1385 mm	42 129 25 97	0.6	
1585 mm	42 129 29 07	0.6	
1785 mm	42 129 29 08	0.7	
1985 mm	42 129 29 10	0.8	

Connecting Pins

With Threaded Ends for Systems U68, U30, S30S, E30

Length	Order No.	kg
Connecting Pins P1CG Min. Diameter 5.3 mm		
650 mm	42 129 20 62	0.1
750 mm	42 129 20 59	0.1
800 mm	42 129 20 42	0.1
900 mm	42 129 20 58	0.2
1000 mm	42 129 20 40	0.2
1050 mm	42 129 20 32	0.2
1200 mm	42 129 20 41	0.2
1350 mm	42 129 20 60	0.2
1400 mm	42 129 20 43	0.2
1600 mm	42 129 20 53	0.3
Connecting Pins P2CG Min. Diameter 6.4 mm		
650 mm	42 128 21 06	0.2
750 mm	42 128 21 16	0.2
800 mm	42 128 21 04	0.2
900 mm	42 129 21 10	0.2
1000 mm	42 128 21 03	0.3
1050 mm	42 128 20 94	0.3
1200 mm	42 128 20 95	0.3
1350 mm	42 128 21 15	0.3
1400 mm	42 128 21 05	0.4
1600 mm	42 128 21 12	0.4
Connecting Pins P3CG Min. Diameter 7.1 mm		
800 mm	42 129 25 52	0.2
900 mm	42 129 24 02	0.3
1000 mm	42 129 25 50	0.3
1050 mm	42 129 24 03	0.3
1200 mm	42 129 25 51	0.3
1350 mm	42 129 24 04	0.4
1400 mm	42 129 25 53	0.4
1600 mm	42 129 25 74	0.5
Connecting Pins P4CG Min. Diameter 8.5 mm		
800 mm	42 129 27 43	0.3
900 mm	42 129 24 06	0.4
1000 mm	42 129 27 44	0.4
1050 mm	42 129 24 07	0.4
1200 mm	42 129 27 45	0.5
1350 mm	42 129 24 08	0.5
1400 mm	42 129 27 46	0.6
1600 mm	42 129 27 61	0.6
1800 mm	42 129 27 62	0.7
2000 mm	42 129 27 63	0.8



Recommended for Sealed Fasteners.
Easy installation,
Installation Tools required (page 12)

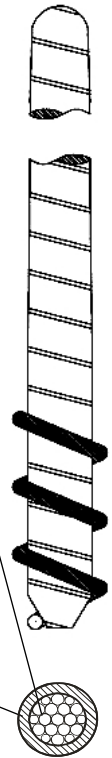

High Tensile
Stainless
Chromium-Nickel
Cable

Stainless
Chromium-
Nickel Steel

Very high wear resistance

Highest level of corrosion resistance as well as very good chemical resistance

Very good for
- high belt tension
- trough / no trough

slightly magnetic

Length	Order No.	kg
Connecting Pins P1S		
Min. Diameter 5.3 mm		
635 mm	42 127 01 19	0.1
735 mm	42 127 01 14	0.1
785 mm	42 127 01 22	0.1
885 mm	42 127 01 25	0.2
985 mm	42 127 01 20	0.2
1035 mm	42 127 01 26	0.2
1185 mm	42 127 01 21	0.2
1335 mm	42 129 20 10	0.2
1385 mm	42 127 01 23	0.2
1585 mm	42 127 15 85	0.3
Connecting Pins P2S		
Min. Diameter 6.4 mm		
635 mm	42 128 04 86	0.2
735 mm	42 128 07 50	0.2
785 mm	42 128 07 85	0.2
885 mm	42 128 08 85	0.2
985 mm	42 128 09 85	0.2
1035 mm	42 128 10 35	0.3
1185 mm	42 128 11 85	0.3
1335 mm	42 128 13 35	0.3
1385 mm	42 128 13 85	0.4
1585 mm	42 128 15 85	0.4
1785 mm	42 128 17 85	0.4
Connecting Pins P3S		
Min. Diameter 7.1 mm		
785 mm	42 129 25 01	0.2
885 mm	42 129 25 15	0.3
985 mm	42 129 25 02	0.3
1035 mm	42 129 25 11	0.3
1185 mm	42 129 25 03	0.3
1335 mm	42 129 25 14	0.4
1385 mm	42 129 25 04	0.4
1585 mm	42 129 25 19	0.5
1785 mm	42 129 25 45	0.5
Connecting Pins P4S		
Min. Diameter 8.5 mm		
785 mm	42 129 27 01	0.3
885 mm	42 129 27 13	0.4
985 mm	42 129 27 02	0.4
1035 mm	42 129 27 06	0.4
1185 mm	42 129 27 03	0.5
1335 mm	42 129 27 12	0.5
1385 mm	42 129 27 04	0.6
1585 mm	42 129 27 09	0.6
1785 mm	42 129 27 15	0.7
1985 mm	42 129 27 10	0.8

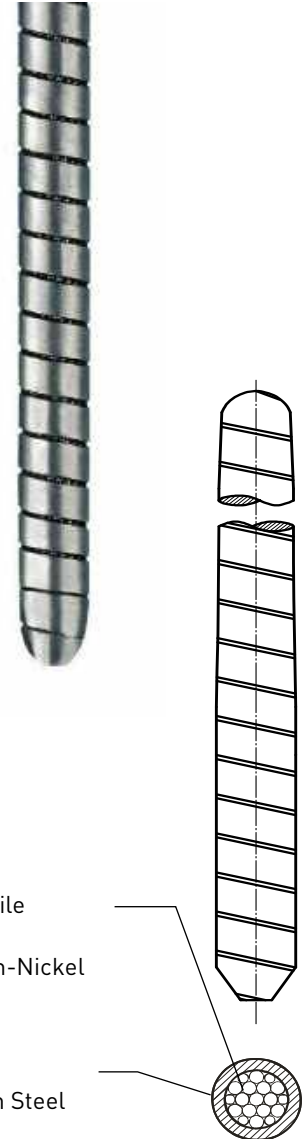

High Tensile
Stainless
Chromium-Nickel
Cable

Stainless
Chromium Steel

High corrosion resistance

Very good for
- high belt tension
- trough / no trough

Connecting Pins

With Threaded Ends for Systems U68, U30, S30S, E30

Length	Order no.	kg
Connecting Pins P1SG		
Min. Diameter 5.3 mm		
650 mm	42 129 20 31	0.1
750 mm	42 129 20 22	0.1
800 mm	42 129 20 15	0.1
900 mm	42 129 20 19	0.2
1000 mm	42 129 20 16	0.2
1050 mm	42 129 20 20	0.2
1200 mm	42 129 20 17	0.2
1350 mm	42 129 13 50	0.2
1400 mm	42 129 20 18	0.2
1600 mm	42 129 20 25	0.3
Connecting Pins P2SG		
Min. Diameter 6.4 mm		
650 mm	42 128 20 85	0.2
750 mm	42 128 20 90	0.2
800 mm	42 128 20 82	0.2
900 mm	42 128 20 83	0.2
1000 mm	42 128 20 79	0.3
1050 mm	42 128 20 84	0.3
1200 mm	42 128 20 77	0.3
1350 mm	42 128 20 89	0.3
1400 mm	42 128 20 80	0.4
1600 mm	42 128 20 81	0.4
1800 mm	42 128 20 88	0.4
Connecting Pins P3SG		
Min. Diameter 7.1 mm		
800 mm	42 129 25 23	0.2
900 mm	42 129 25 24	0.3
1000 mm	42 129 25 20	0.3
1050 mm	42 129 25 25	0.3
1200 mm	42 129 25 21	0.3
1350 mm	42 129 25 32	0.4
1400 mm	42 129 25 22	0.4
1600 mm	42 129 25 30	0.5
1800 mm	42 129 25 31	0.5
Connecting Pins P4SG		
Min. Diameter 8.5 mm		
800 mm	42 129 27 20	0.3
900 mm	42 129 27 22	0.4
1000 mm	42 129 27 16	0.4
1050 mm	42 129 27 23	0.4
1200 mm	42 129 27 30	0.5
1350 mm	42 129 27 47	0.5
1400 mm	42 129 27 18	0.6
1600 mm	42 129 27 21	0.6
1800 mm	42 129 27 26	0.7
2000 mm	42 129 27 65	0.8



Recommended for Sealed Fasteners.
Easy installation,
Installation Tools required
(page 12)

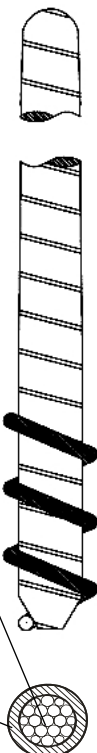

High Tensile
Stainless
Chromium-
Nickel
Cable

Stainless
Chromium
Steel

High corrosion resistance

Very good for
- high belt tension
- trough / no trough

mato

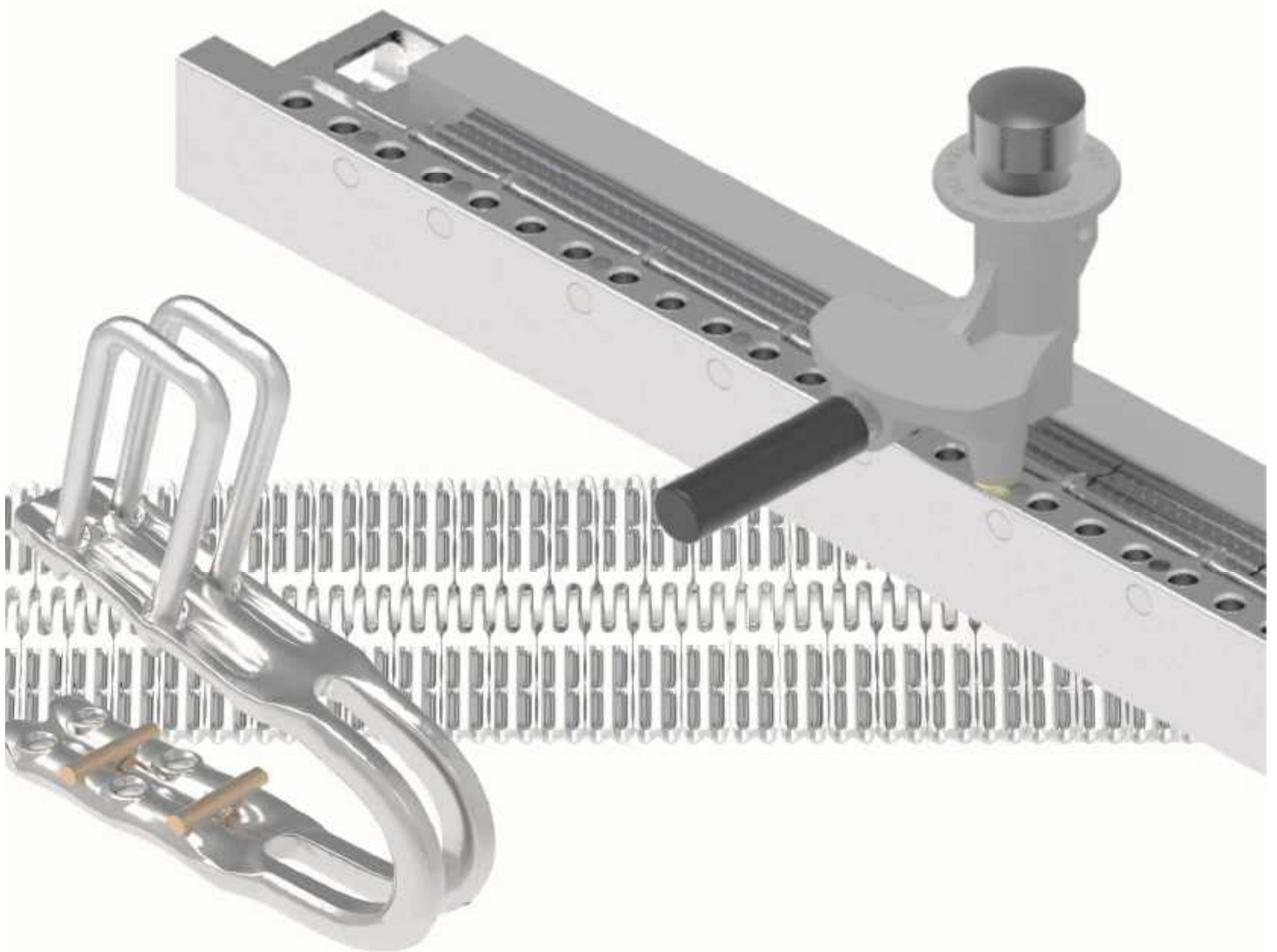

Selection Chart

Hammer Installed Plate Fasteners

The **Systems H30 and H60** are the strongest Hammer Systems. Belt ends with H30 / H60 are connectable to beltends with U30 or S30S or E30. Its outstanding features are:

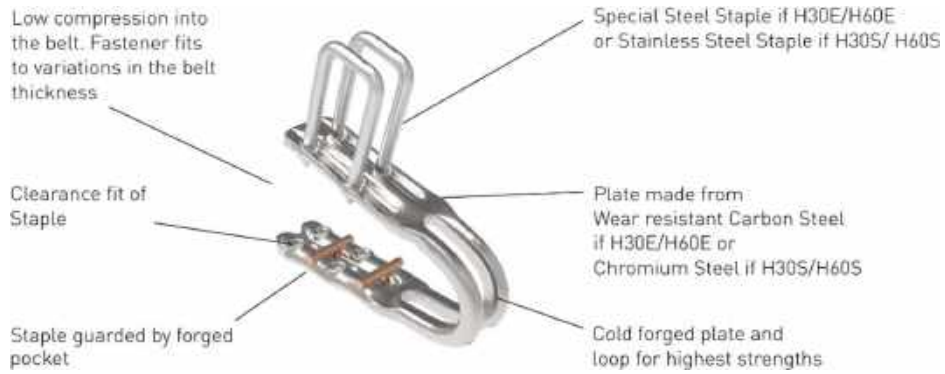

The **MR30-System** is a simple and easy to use Hammer System. In comparison to other Wide Plate Fasteners, the MR30-System has a long life time and can be installed within a short time.

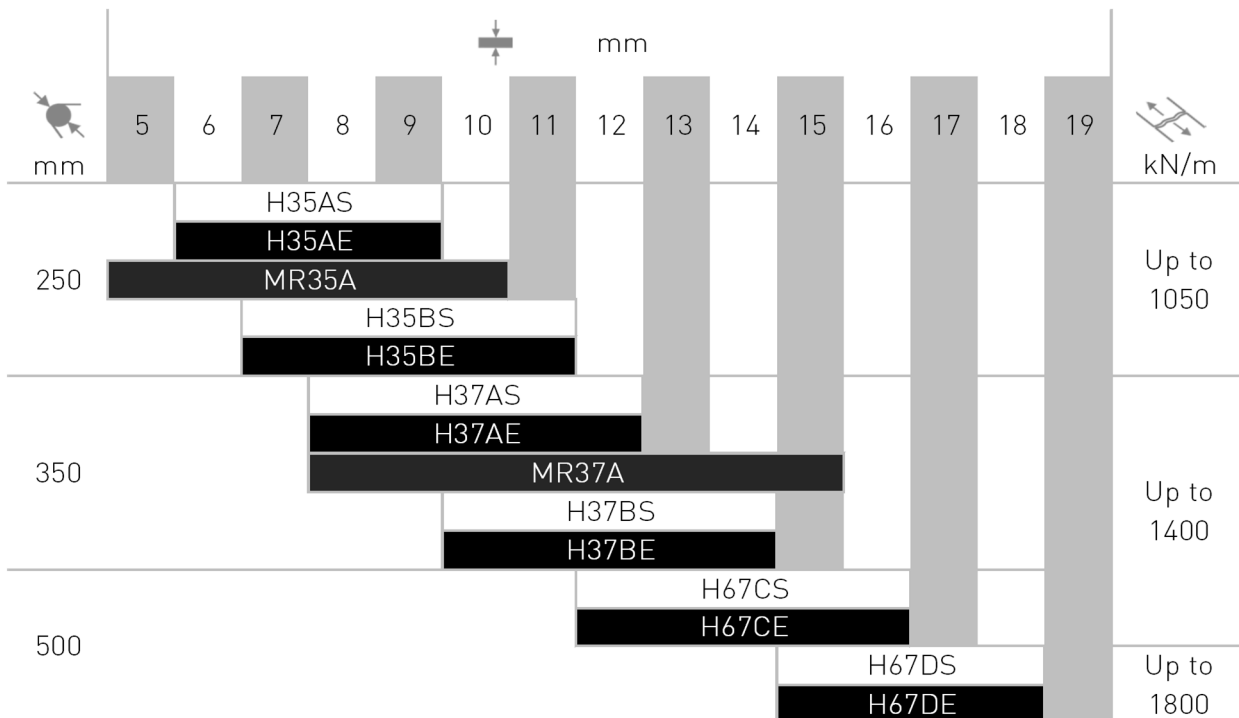
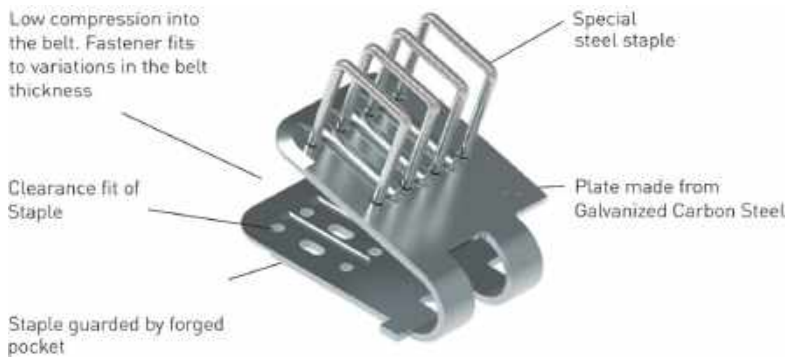

Materials

Plate

Cr (S) Steel

Carbon

Staple

CrNi (SS) Steel

Special Steel

Thicker belts can be skived (covers) to fit

Belt Width	Belt Thickness	Order No.	kg
------------	----------------	-----------	----

Belt Fastener H35AS - Standard
 Belt Strength up to 1050 kN/m Minimum Pulley Diameter 250 mm

up to 650 mm	6 - 9 mm	41 118 02 19	2.0
up to 800 mm	6 - 9 mm	41 118 02 20	2.2
up to 900 mm	6 - 9 mm	41 116 22 17	2.4
up to 1000 mm	6 - 9 mm	41 116 22 18	2.7
up to 1050 mm	6 - 9 mm	41 116 22 19	2.9
up to 1200 mm	6 - 9 mm	41 116 22 30	3.3
up to 1350 mm	6 - 9 mm	41 116 22 21	3.7
up to 1400 mm	6 - 9 mm	41 116 22 22	3.9
up to 1600 mm	6 - 9 mm	41 116 22 24	4.4

Belt Fastener H35BS - Standard
 Belt Strength up to 1050 kN/m Minimum Pulley Diameter 250 mm

up to 650 mm	7 - 11 mm	41 118 02 04	2.0
up to 800 mm	7 - 11 mm	41 118 02 05	2.2
up to 900 mm	7 - 11 mm	41 116 22 26	2.4
up to 1000 mm	7 - 11 mm	41 116 22 27	2.7
up to 1050 mm	7 - 11 mm	41 116 22 28	2.9
up to 1200 mm	7 - 11 mm	41 116 20 30	3.3
up to 1350 mm	7 - 11 mm	41 116 18 30	3.8
up to 1400 mm	7 - 11 mm	41 116 22 31	3.9
up to 1600 mm	7 - 11 mm	41 116 22 33	4.4

Belt Fastener H37AS - Standard
 Belt Strength up to 1400 kN/m Minimum Pulley Diameter 350 mm

up to 650 mm	8 - 12 mm	41 118 01 98	1.9
up to 800 mm	8 - 12 mm	41 118 02 24	2.5
up to 900 mm	8 - 12 mm	41 116 22 62	2.9
up to 1000 mm	8 - 12 mm	41 116 22 63	3.3
up to 1050 mm	8 - 12 mm	41 116 22 64	3.5
up to 1200 mm	8 - 12 mm	41 116 22 65	3.9
up to 1350 mm	8 - 12 mm	41 116 22 66	4.5
up to 1400 mm	8 - 12 mm	41 116 22 67	4.6
up to 1600 mm	8 - 12 mm	41 116 22 69	5.3

Belt Fastener H37BS - Standard
 Belt Strength up to 1400 kN/m Minimum Pulley Diameter 350 mm

up to 650 mm	10 - 14 mm	41 118 02 06	1.9
up to 800 mm	10 - 14 mm	41 118 02 07	2.5
up to 900 mm	10 - 14 mm	41 116 22 71	2.9
up to 1000 mm	10 - 14 mm	41 116 22 72	3.3
up to 1050 mm	10 - 14 mm	41 116 22 73	3.5
up to 1200 mm	10 - 14 mm	41 116 22 74	4.0
up to 1350 mm	10 - 14 mm	41 116 22 75	4.5
up to 1400 mm	10 - 14 mm	41 116 22 76	4.7
up to 1600 mm	10 - 14 mm	41 116 22 78	5.3

Belt Fastener H67CS - Standard
 Belt Strength up to 1800 kN/m Minimum Pulley Diameter 500 mm

up to 900 mm	12 - 16 mm	41 118 50 24	4.5
up to 1000 mm	12 - 16 mm	41 118 50 25	5.0
up to 1050 mm	12 - 16 mm	41 118 50 26	5.3
up to 1200 mm	12 - 16 mm	41 118 50 16	6.0
up to 1350 mm	12 - 16 mm	41 118 50 27	6.7
up to 1400 mm	12 - 16 mm	41 118 50 28	6.9
up to 1600 mm	12 - 16 mm	41 118 50 29	7.9

Belt Fastener H67DS - Standard
 Belt Strength up to 1800 kN/m Minimum Pulley Diameter 500 mm

up to 900 mm	15 - 18 mm	41 118 50 30	4.5
up to 1000 mm	15 - 18 mm	41 118 50 31	5.0
up to 1050 mm	15 - 18 mm	41 118 50 32	5.3
up to 1200 mm	15 - 18 mm	41 118 50 20	6.0
up to 1350 mm	15 - 18 mm	41 118 50 33	6.7
up to 1400 mm	15 - 18 mm	41 118 50 34	6.9
up to 1600 mm	15 - 18 mm	41 118 50 35	7.9



- Low compression into the belt
- Stainless steel staples
- Staple guard
- Cold forged plate with loops for highest strengths
- High wear resistant plate material (chromium steel)
- Fits to variations in belt thickness

Staple Material: **Stainless Steel**
 Plate Material: **Stainless Chromium Steel**

Pricing: based on boxes with 2 Fastener Strips with length according belt width, (can be shortened individually). Content is sufficient for one complete lace. (without Connecting Pin)



- Low compression into the belt
- Stainless steel staples
- Staple guard
- Cold forged plate with loops for highest strengths
- High wear resistant plate material (chromium steel)
- Fits to variations in belt thickness

Staple Material: **Stainless Steel**
 Plate Material: **Stainless Chromium Steel**

Pricing: based on boxes with 2 Fastener Strips with length according belt width, (can be shortened individually). Content is sufficient for one complete lace. (without Connecting Pin)

Belt Width	Belt Thickness	Order No.	kg
------------	----------------	-----------	----

Belt Fastener H35AE - Standard

Belt Strength up to 1050 kN/m		Minimum Pulley Diameter 250 mm	
up to 650 mm	6 - 9 mm	41 118 02 15	1.7
up to 800 mm	6 - 9 mm	41 118 02 16	2.1
up to 900 mm	6 - 9 mm	41 116 20 00	2.4
up to 1000 mm	6 - 9 mm	41 116 20 01	2.7
up to 1050 mm	6 - 9 mm	41 116 20 02	2.9
up to 1200 mm	6 - 9 mm	41 116 20 03	3.3
up to 1350 mm	6 - 9 mm	41 116 20 04	3.7
up to 1400 mm	6 - 9 mm	41 116 20 05	3.9
up to 1600 mm	6 - 9 mm	41 116 20 07	4.4



Belt Fastener H35BE - Standard

Belt Strength up to 1050 kN/m		Minimum Pulley Diameter 250 mm	
up to 650 mm	7 - 11 mm	41 118 02 08	1.7
up to 800 mm	7 - 11 mm	41 118 01 34	2.1
up to 900 mm	7 - 11 mm	41 116 20 09	2.4
up to 1000 mm	7 - 11 mm	41 116 20 10	2.7
up to 1050 mm	7 - 11 mm	41 116 20 11	2.9
up to 1200 mm	7 - 11 mm	41 116 20 12	3.3
up to 1350 mm	7 - 11 mm	41 116 20 13	3.7
up to 1400 mm	7 - 11 mm	41 116 20 14	3.9
up to 1600 mm	7 - 11 mm	41 116 20 16	4.4

Belt Fastener H37AE - Standard

Belt Strength up to 1400 kN/m		Minimum Pulley Diameter 350 mm	
up to 650 mm	8 - 12 mm	41 118 02 23	1.9
up to 800 mm	8 - 12 mm	41 118 01 97	2.5
up to 900 mm	8 - 12 mm	41 116 21 45	2.9
up to 1000 mm	8 - 12 mm	41 116 21 46	3.3
up to 1050 mm	8 - 12 mm	41 116 21 47	3.5
up to 1200 mm	8 - 12 mm	41 116 21 48	3.9
up to 1350 mm	8 - 12 mm	41 116 21 49	4.5
up to 1400 mm	8 - 12 mm	41 116 21 50	4.6
up to 1600 mm	8 - 12 mm	41 116 21 52	5.3

Belt Fastener H37BE - Standard

Belt Strength up to 1400 kN/m		Minimum Pulley Diameter 350 mm	
up to 650 mm	10 - 14 mm	41 118 02 00	1.9
up to 800 mm	10 - 14 mm	41 118 01 29	2.5
up to 900 mm	10 - 14 mm	41 116 21 54	2.9
up to 1000 mm	10 - 14 mm	41 116 21 55	3.3
up to 1050 mm	10 - 14 mm	41 116 21 56	3.5
up to 1200 mm	10 - 14 mm	41 116 21 57	3.9
up to 1350 mm	10 - 14 mm	41 116 21 58	4.5
up to 1400 mm	10 - 14 mm	41 116 21 59	4.6
up to 1600 mm	10 - 14 mm	41 116 21 61	5.3

Belt Fastener H67CE - Standard

Belt Strength up to 1800 kN/m		Minimum Pulley Diameter 500 mm	
up to 900 mm	12 - 16 mm	41 118 49 80	4.5
up to 1000 mm	12 - 16 mm	41 118 49 81	5.0
up to 1050 mm	12 - 16 mm	41 118 49 82	5.3
up to 1200 mm	12 - 16 mm	41 118 50 00	6.0
up to 1350 mm	12 - 16 mm	41 118 49 83	6.7
up to 1400 mm	12 - 16 mm	41 118 49 84	6.9
up to 1600 mm	12 - 16 mm	41 118 49 85	7.9

Belt Fastener H67DE - Standard

Belt Strength up to 1800 kN/m		Minimum Pulley Diameter 500 mm	
up to 900 mm	15 - 18 mm	41 118 49 86	4.5
up to 1000 mm	15 - 18 mm	41 118 49 87	5.0
up to 1050 mm	15 - 18 mm	41 118 49 88	5.3
up to 1200 mm	15 - 18 mm	41 118 50 04	6.0
up to 1350 mm	15 - 18 mm	41 118 49 89	6.7
up to 1400 mm	15 - 18 mm	41 118 49 90	6.9
up to 1600 mm	15 - 18 mm	41 118 49 91	7.9

- Low compression in the belt
- Staple guard
- Cold forged plate with loops for highest strengths
- Wear resistant plate material (carbon steel)
- High tensile special steel staples
- Fits to variations in belt thickness

Staple Material: **Special Steel**
 Plate Material: **Carbon Steel**

Pricing: based on boxes with 2 Fastener Strips with length according belt width, (can be shortened individually). Content is sufficient for one complete lace. (without Connecting Pin)



- Low compression in the belt
- Staple guard
- Cold forged plate with loops for highest strengths
- Wear resistant plate material (carbon steel)
- High tensile special steel staples
- Fits to variations in belt thickness

Staple Material: **Special Steel**
 Plate Material: **Carbon Steel**

Pricing: based on boxes with 2 Fastener Strips with length according belt width, (can be shortened individually). Content is sufficient for one complete lace. (without Connecting Pin)

Belt Width	Order No.	kg
------------	-----------	----

Installation Unit HTA H30 - Aluminium Frame

Aluminium Frame. The Installation Units HTA H30 are used for the Fastener sizes H35A and H35 as well as H37A and H37. Simply turn the Comb Pins to the required Fastener size. The Installation Units HTA H60 are used for the Fastener sizes H67CE and H67DE. The low weight of the Installation Unit allows easy handling

400 mm	41 119 04 00	14.2
1000 mm	41 119 10 00	24.6
1200 mm	41 119 12 00	26.4
1400 mm	41 119 14 00	28.3
1600 mm	41 119 16 00	31.0

Installation Unit HTA H60 - Aluminium Frame

400 mm	41 119 12 65	14.3
1000 mm	41 119 12 66	24.7
1200 mm	41 119 12 67	26.5
1400 mm	41 119 12 68	28.4
1600 mm	41 119 12 69	

Installation Unit HTS H37 - Steel Frame

Steel Frame. The Installation Unit HTS H37 is used to install the Fastener sizes H37A and H37. The Installation Unit HTS H67 C/D is used to install the Fastener sizes H67C and H67D.

600 mm	41 119 06 02	16.6
--------	--------------	------

Installation Unit HTS H67 C/D - Steel Frame

600 mm	41 119 06 05	16.6
--------	--------------	------

Hammer

Hammer HM (2kg) For the use with Lacing Head HK	44 130 16 03	2.1
--	--------------	-----

Pneumatic Hammer

Pneumatic Hammer Complete H30/H60 Maximum Operating Pressure 6 bar. For installing Fasteners H30 / H60, incl. Lacing Head.	46 100 10 60	9.8
---	--------------	-----

Belt Skiver

Belt Skiver 17/20 - H30/H60	41 129 58 50	0.8
Spare Blade Belt Skiver 17/20	41 129 58 51	0.1

Accessories

Hacksaw	44 130 16 07	0.1
---------	--------------	-----

Standard equipment of all Installation Units includes a Hammer Frame and a Lacing Head.



Belt Width	Order No.	kg	
Lacing Head			
Lacing Head for installing fasteners H30 / H60 manually by hammer			
Lacing Head HK H30	41 117 01 00	3.6	
Lacing Head HK H60	41 117 01 67	3.9	
Pneumatic Hammer			
Maximum Operating Pressure 6 bar. For installing Fasteners H30 / H60. Delivery without Head.			
Pneumatic Hammer H30/H60	46 000 10 00	6.9	
Head Complete for Pneumatic Hammer			
Pneumatic Hammer-Lacing Head. For installing Fasteners H30 / H60. Suitable for Pneumatic Hammer Nr. 46 000 10 00. Suitable for all Hammer Frames H30 / H60			
Pneumatic Hammer Head H30/H60	46 000 10 50	2.9	
Punch for Pneumatic Hammer			
Punch for Pneumatic Hammer H30/H60	46 000 10 70	0.6	
Head Complete for Electric Hammer (SDS-MAX Take-Up)			
Electric Hammer-Lacing Head For installing Fasteners H30 / H60. Suitable for all brands with SDS-MAX take-up. (Minimum of 12 Joule necessary for installation!)			
Electric Hammer Head H30/H60	43 333 02 00	4.2	
Punch for Electric Hammer (SDS-MAX Take-Up)			
Punch for Electric Hammer H30/H60	43 333 03 00	0.6	

Belt Width	Belt Thickness	Order No.	kg
Belt Fastener MR35A - Standard			
Belt Strength up to 1050 kN/m		Minimum Pulley Diameter 250 mm	
up to 1000 mm	5 - 10 mm	46 000 10 37	3.2
up to 1200 mm	5 - 10 mm	46 000 10 39	3.5
up to 1400 mm	5 - 10 mm	46 000 10 41	3.9
Belt Fastener MR37A - Standard			
Belt Strength up to 1400 kN/m		Minimum Pulley Diameter 350 mm	
up to 1000 mm	10 - 15 mm	46 000 10 45	3.5
up to 1200 mm	10 - 15 mm	46 000 10 47	4.2
up to 1400 mm	10 - 15 mm	46 000 10 49	4.9



- Low compression in the belt
 - Staple Guard
 - Wear resistant plate material (galvanized)
 - High tensile special steel staples
 - Fits to variations in belt thickness
- Staple Material: **Special Steel**
 Plate Material: **Carbon Steel**
- 4.9 Units: based on boxes with 2 Fastener Strips with length according belt width, (can be shortened individually). Content is sufficient for one complete lace. (without Connecting Pin)

Installation Units and Accessories

for Hammer Installed Systems MR30

Belt Width	Order No.	kg
Installation Unit MRTA MR30		
Standard equipment of Installation Units (Aluminium Frame) includes a Hammer Frame and a Lacing Head.		
1000 mm	46 000 10 52	21.50
1200 mm	46 000 10 53	25.10
1400 mm	46 000 10 54	28.70
Hammer		
Hammer H3 (3kg)	46 000 00 78	3.60
Lacing Head		
Hammer-Lacing Head. For installing the Fastener series MR30		
Lacing Head MRK MR30	46 000 10 56	3.20
Head Complete for Electric Hammer (SDS-MAX Take-Up)		
Electric Hammer-Lacing Head. For installing Fasteners MR30. Suitable for all brands with SDS-MAX Take-Up. <i>(Minimum of 12 Joule necessary for installation!)</i>		
Electric Hammer Head MR30	46 333 02 00	2.90
Punch for Electric Hammer (SDS-MAX Take-Up)		
Punch for Electric Hammer Head MR30	46 333 03 00	0.6



Connecting Pins and Accessories see pages 24 - 29 and page 12.

Length	Order No.	kg
Connecting Pins P1S		
Min. Diameter 5.3 mm		
635 mm	42 127 01 19	0.1
735 mm	42 127 01 14	0.1
785 mm	42 127 01 22	0.1
885 mm	42 127 01 25	0.2
985 mm	42 127 01 20	0.2
1035 mm	42 127 01 26	0.2
1185 mm	42 127 01 21	0.2
1335 mm	42 129 20 10	0.2
1385 mm	42 127 01 23	0.2
1585 mm	42 127 15 85	0.3
Connecting Pins P2S		
Min. Diameter 6.4 mm		
635 mm	42 128 04 86	0.2
735 mm	42 128 07 50	0.2
785 mm	42 128 07 85	0.2
885 mm	42 128 08 85	0.2
985 mm	42 128 09 85	0.2
1035 mm	42 128 10 35	0.3
1185 mm	42 128 11 85	0.3
1335 mm	42 128 13 35	0.3
1385 mm	42 128 13 85	0.4
1585 mm	42 128 15 85	0.4
1785 mm	42 128 17 85	0.4
Connecting Pins P3S		
Min. Diameter 7.1 mm		
785 mm	42 129 25 01	0.2
885 mm	42 129 25 15	0.3
985 mm	42 129 25 02	0.3
1035 mm	42 129 25 11	0.3
1185 mm	42 129 25 03	0.3
1335 mm	42 129 25 14	0.4
1385 mm	42 129 25 04	0.4
1585 mm	42 129 25 19	0.5
1785 mm	42 129 25 45	0.5
Connecting Pins P4S		
Min. Diameter 8.5 mm		
785 mm	42 129 27 01	0.3
885 mm	42 129 27 13	0.4
985 mm	42 129 27 02	0.4
1035 mm	42 129 27 06	0.4
1185 mm	42 129 27 03	0.5
1335 mm	42 129 27 12	0.5
1385 mm	42 129 27 04	0.6
1585 mm	42 129 27 09	0.6
1785 mm	42 129 27 15	0.7
1985 mm	42 129 27 10	0.8

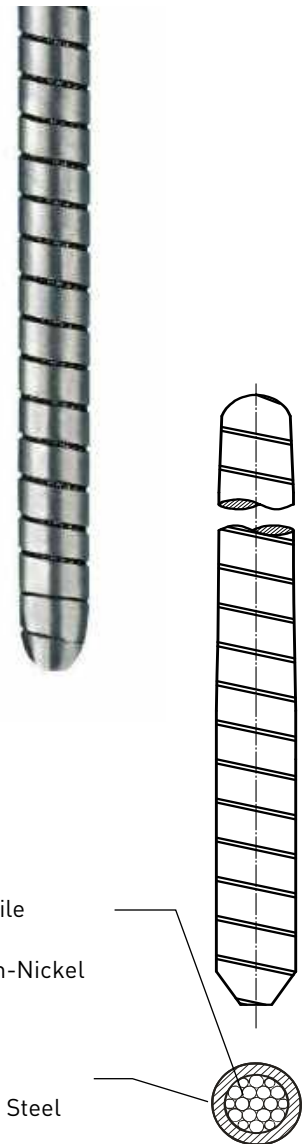

High corrosion resistance

Very good for
 - high belt tension
 - trough / no trough

Length	Order No.	kg
Connecting Pins P1E		
Min. Diameter 5.3 mm		
635 mm	42 134 06 35	0.5
735 mm	42 134 07 35	0.1
785 mm	42 134 07 85	0.1
885 mm	42 134 08 85	0.2
985 mm	42 134 09 85	0.2
1035 mm	42 134 10 35	0.2
1185 mm	42 134 11 85	0.2
1335 mm	42 134 13 35	0.2
1385 mm	42 134 13 85	0.2
1585 mm	42 134 15 85	0.3
Connecting Pins P2E		
Min. Diameter 6.4 mm		
635 mm	42 135 06 35	0.3
735 mm	42 135 07 35	0.2
785 mm	42 135 07 85	0.2
885 mm	42 135 08 85	0.2
985 mm	42 135 09 85	0.2
1035 mm	42 135 10 35	0.3
1185 mm	42 135 11 85	0.3
1335 mm	42 135 13 35	0.3
1385 mm	42 135 13 85	0.4
1585 mm	42 135 15 85	0.4
Connecting Pins P3E		
Min. Diameter 7.1 mm		
735 mm	42 136 07 35	0.2
785 mm	42 136 07 85	0.2
885 mm	42 136 08 85	0.3
985 mm	42 136 09 85	0.3
1035 mm	42 136 10 35	0.3
1185 mm	42 136 11 85	0.3
1335 mm	42 136 13 35	0.4
1385 mm	42 136 13 85	0.4
1585 mm	42 136 15 85	0.5
Connecting Pins P4E		
Min. Diameter 8.5 mm		
785 mm	42 139 47 85	0.3
885 mm	42 139 48 85	0.4
985 mm	42 139 49 85	0.4
1035 mm	42 139 40 35	0.4
1185 mm	42 139 41 85	0.5
1335 mm	42 139 43 35	0.5
1385 mm	42 139 43 85	0.6
1585 mm	42 139 45 85	0.6
Connecting Pins P5E		
Min. Diameter 10.5 mm		
785 mm	42 139 57 85	0.6
885 mm	42 139 58 85	0.6
985 mm	42 139 59 85	0.7
1035 mm	42 139 50 35	0.7
1185 mm	42 139 51 85	0.8
1335 mm	42 139 53 35	1.0
1385 mm	42 139 53 85	1.0
1585 mm	42 139 55 85	1.1

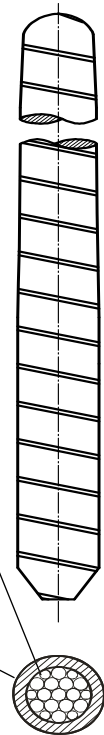

High Tensile
Stainless
Chromium-
Nickel Cable

Special Steel

Very good for
- high belt tension
- trough / no trough

Length	Order No.	kg
Connecting Pins L1		
Min. Diameter 5.3 mm		
635 mm	42 126 06 35	0.1
735 mm	42 126 07 35	0.1
785 mm	42 126 07 85	0.1
885 mm	42 126 08 85	0.1
985 mm	42 126 09 85	0.1
1035 mm	42 126 10 52	0.1
1185 mm	42 126 11 85	0.2
1335 mm	42 126 13 50	0.2
1385 mm	42 126 13 85	0.2
1585 mm	42 126 15 85	0.2
Connecting Pins L2		
Min. Diameter 5.6 mm		
635 mm	42 129 06 35	0.1
735 mm	42 125 13 10	0.1
785 mm	42 129 12 01	0.1
885 mm	42 125 09 00	0.1
985 mm	42 125 09 85	0.2
1035 mm	42 125 10 35	0.2
1185 mm	42 125 11 85	0.2
1335 mm	42 125 13 35	0.2
1385 mm	42 125 13 85	0.2
1585 mm	42 125 15 85	0.3
Connecting Pins L3		
Min. Diameter 6.9 mm		
735 mm	42 129 15 86	0.2
785 mm	42 129 07 85	0.2
885 mm	42 129 09 00	0.2
985 mm	42 129 09 85	0.2
1035 mm	42 129 10 52	0.3
1185 mm	42 129 11 85	0.3
1335 mm	42 129 10 53	0.3
1385 mm	42 129 13 85	0.3
1585 mm	42 129 15 85	0.4

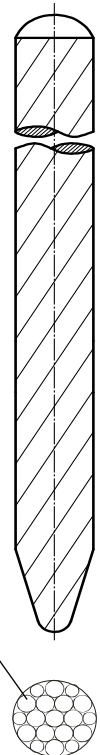

High Tensile Galvanised Cable

Good for - trough

mato

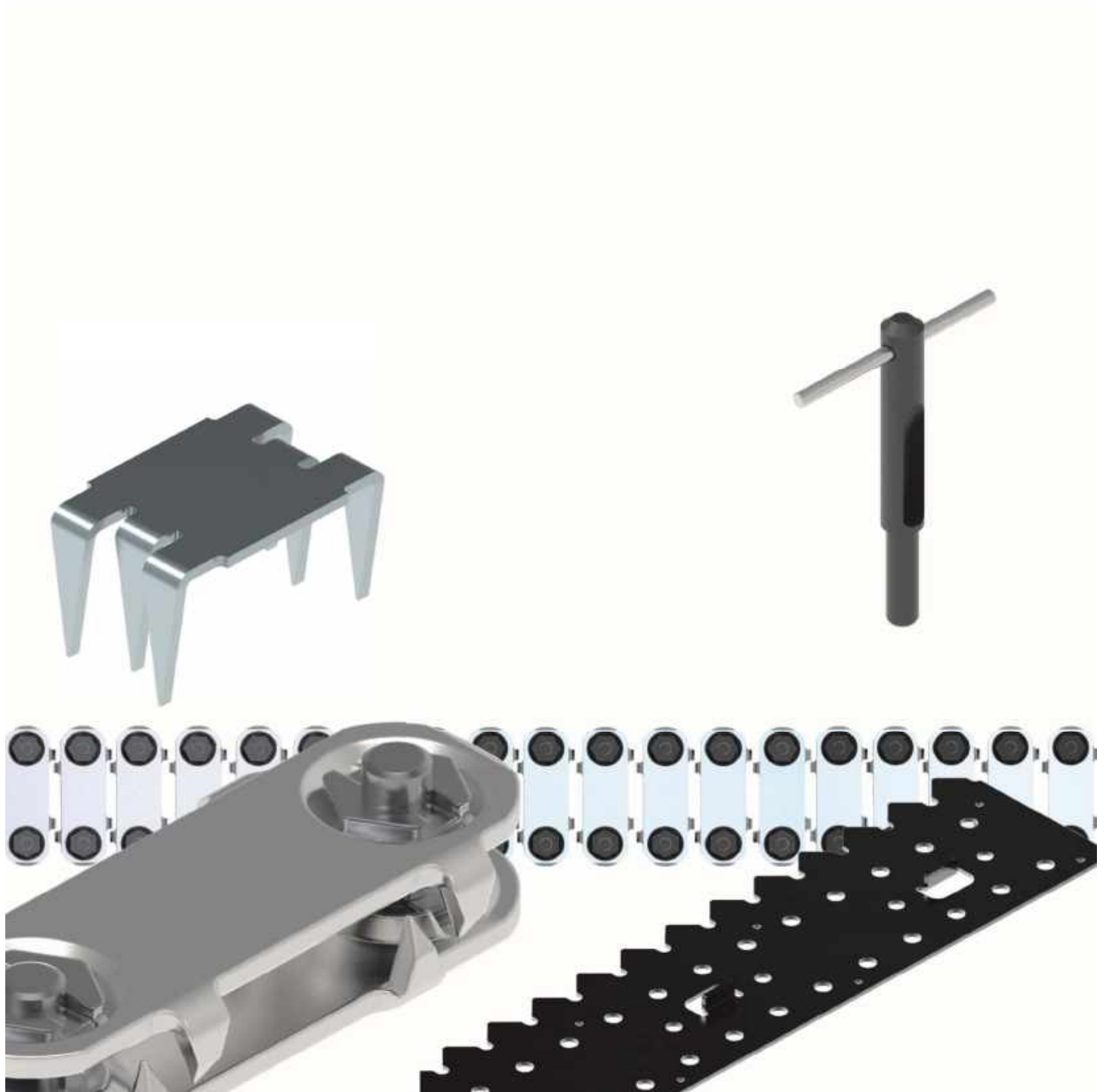

The Bolt Plate Screw System MS is used for belt splicing and rip repairs. It is easy to install. The Fastener guarantees good compression into the belt (vice like effect)

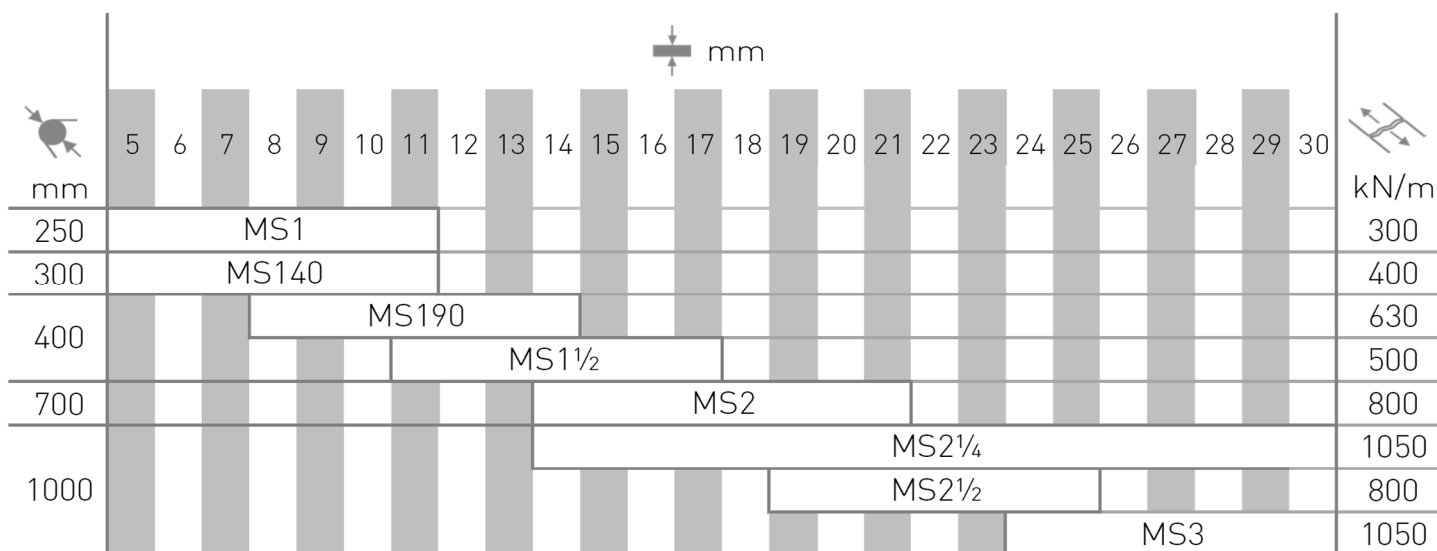

Description	Width	Order No.	kg
Belt Fastener MS - Box			
Content 25 units			
MS1	750 mm	46 100 60 10	1.4
MS140	750 mm	46 100 60 53	1.8
MS190	750 mm	46 100 60 54	2.0
MS1½	950 mm	46 100 60 30	2.5
MS2	1050 mm	46 100 60 40	3.3
MS2¼	1050 mm	46 000 11 72	4.6
Belt Fastener MS - Box			
Content 10 units			
MS2½	500 mm	46 100 60 60	2.7
MS3	500 mm	46 000 13 54	3.0



Material Upper / Lower Plate: **Special Steel**
Steel Series Fastener for general application

Description	Width	Order No.	kg
Belt Fastener MS - Bucket			
Content 100 units			
MS1	3000 mm	46 000 09 82	5.7
MS140	3000 mm	46 000 09 78	7.2
MS190	3000 mm	46 000 09 79	8.1
MS1½	3800 mm	46 000 09 83	9.8
MS2	4200 mm	46 000 09 84	13.3
MS2¼	4200 mm	46 000 11 73	18.3
Belt Fastener MS - Bucket			
Content 50 units			
MS2½	2500 mm	41 178 17 71	13.5
MS3	2500 mm	41 178 17 72	15.0



Material Upper / Lower Plate:
Special Steel
Steel Series Fastener for general application

*Hard Plate and Stainless versions are available on request

Description	Order No.	kg
Belt Punch		
SL1-140-190	46 100 67 23	0.1
SL1½-2-2¼	46 100 67 24	0.1
SL2½-3	46 100 67 25	0.2
Power Punch		
ML1-140-190	46 100 67 29	0.1
ML1½-2-2¼	46 100 67 30	0.1
ML2½-3	46 100 67 31	0.1
Hand Nut Tightener		
HS1-140-190	46 100 67 26	0.2
HS1½-2-2¼	46 100 67 27	0.2
HS2½-3	46 100 67 28	0.3
Brace Nut Tightener		
HB1-140-190	46 100 66 05	0.1
HB1½-2-2¼	46 100 66 10	0.1
HB2½-3	46 100 66 15	0.1
Power Nut Tightener		
MB1-140-190	46 100 67 32	0.1
MB1½-2-2¼	46 100 67 33	0.1
MB2½-3	46 100 67 34	0.1
Bolt Breaker		
SB1-140-190	46 100 67 20	0.4
SB1½-2-2¼	46 100 67 21	0.7
SB2½-3	46 100 67 22	1.2
Quick Change Chuck		
SK1-3	46 100 67 42	0.2



Additional accessories are available upon request

Description	Width	Order No.	kg
Templates for MS1			
LL-MS1-600	600 mm	46 100 63 02	1.0
LL-MS1-750	750 mm	46 100 63 30	1.2
LL-MS1-900	900 mm	46 100 63 23	1.4
LL-MS1-1050	1050 mm	46 100 61 25	1.6
LL-MS1-1200	1200 mm	46 100 63 09	1.8
Templates for MS140			
LL-MS140-600	600 mm	46 100 63 00	1.0
LL-MS140-750	750 mm	46 100 63 28	1.2
LL-MS140-900	900 mm	46 100 63 21	1.4
LL-MS140-1050	1050 mm	46 100 62 60	1.6
LL-MS140-1200	1200 mm	46 100 63 07	1.8
Templates for MS190			
LL-MS190-600	600 mm	46 100 63 01	1.0
LL-MS190-750	750 mm	46 100 63 29	1.3
LL-MS190-900	900 mm	46 100 63 22	1.6
LL-MS190-1050	1050 mm	46 100 62 61	1.9
LL-MS190-1200	1200 mm	46 100 63 08	2.2
LL-MS190-1500	1500 mm	46 100 63 35	2.9
Templates for MS1½			
LL-MS1½-600	600 mm	46 100 63 04	1.0
LL-MS1½-750	750 mm	46 100 63 32	1.1
LL-MS1½-900	900 mm	46 100 63 25	1.4
LL-MS1½-1050	1050 mm	46 100 62 62	1.6
LL-MS1½-1200	1200 mm	46 100 63 11	1.8
LL-MS1½-1500	1500 mm	46 100 63 37	2.3
Templates for MS2			
LL-MS2-600	600 mm	46 100 63 05	1.1
LL-MS2-750	750 mm	46 100 63 33	1.4
LL-MS2-900	900 mm	46 100 63 26	1.6
LL-MS2-1050	1050 mm	46 100 63 38	1.9
LL-MS2-1200	1200 mm	46 100 63 12	1.9
LL-MS2-1500	1500 mm	46 100 63 39	2.8
Templates for MS2¼			
LL-MS2¼-600	600 mm	46 100 67 36	1.3
LL-MS2¼-750	750 mm	46 100 67 37	1.7
LL-MS2¼-900	900 mm	46 100 67 38	2.1
LL-MS2¼-1050	1050 mm	46 100 67 39	2.4
LL-MS2¼-1200	1200 mm	46 100 67 40	2.8
LL-MS2¼-1500	1500 mm	46 100 67 41	3.6
Templates for MS2½			
LL-MS2½-600	600 mm	46 100 63 42	1.6
LL-MS2½-750	750 mm	46 100 63 43	2.0
LL-MS2½-900	900 mm	46 100 63 44	2.4
LL-MS2½-1050	1050 mm	46 100 63 40	2.8
LL-MS2½-1200	1200 mm	46 100 63 13	3.2
LL-MS2½-1500	1500 mm	46 100 63 41	4.0
Templates for MS3			
LL-MS3-900	900 mm	46 100 63 45	2.4
LL-MS3-1050	1050 mm	46 100 63 46	2.8
LL-MS3-1200	1200 mm	46 100 63 47	3.2
LL-MS3-1500	1500 mm	46 100 63 48	4.0



Template for punching and keeping the correct pitch

Additional accessories are available upon request

Description	Belt Thickness	Order No.	kg
Belt Fastener S82 Side Length 8 mm, Fastener Width 12 mm			
S82 (200)	up to 4 mm	42 701 20 00	0.2
Belt Fastener S83 Side Length 10 mm, Fastener Width 14 mm			
S83 (201)	up to 6 mm	42 701 20 10	0.2
Belt Fastener S84 Side Length 12 mm, Fastener Width 17 mm			
S84 (202)	up to 8 mm	42 701 20 20	0.5
Belt Fastener S85 Side Length 16 mm, Fastener Width 23 mm			
S85 (203)	up to 10 mm	42 701 20 30	0.9
Belt Fastener S86 Side Length 20 mm, Fastener Width 25 mm			
S86 (204)	up to 13 mm	42 701 20 40	1.5
Belt Fastener S87 Side Length 23 mm, Fastener Width 30 mm			
S87 (205)	up to 15 mm	42 701 20 50	2.4
Belt Fastener S88 Side Length 29 mm, Fastener Width 35 mm			
S88 (206)	up to 18 mm	42 701 20 60	4.0
Belt Fastener S89 Side Length 38 mm, Fastener Width 43 mm			
S89 (207)	up to 21 mm	42 701 20 70	6.6



- Fastener Installation without lacing tool
- For rip repairs

Material:
Special Steel

Packing units:
100 pieces per pack

Description Order No. kg

Multiface 1.5 BOND in double cartridge inclusive 2 static mixers

Multiface® has been specially developed for maintenance of conveyor belts made of rubber, PVC or PU as well as for the bonding of abrasion resistant lining. **Multiface®** is even usable for materials such as metal, glass, ceramics, wood, textile and many other plastic materials, when a high strength and permanently elastic gluing with a very thin

MF-1.5 -25 (2x12.5 g) (No Caulking Gun necessary)	38 078 18	0.1
MF-1.5 -50 (2x25 g)	38 078 25	0.1
MF-1.5 -200 (2x100 g)	38 078 32	0.2
MF-1.5 -400 (2x200 g)	38 078 49	0.4

Quick drying, 65 ShoreA, No hazardous product, Food contact approved according to EG 1935/2004. Color of BOND black.

MATO BOND Starter Set 200

Starter Set 200	38 078 56	3.5
-----------------	-----------	-----

including:

- 1 Double Cartridge MF-1.5 -200 (2x100 g)
(Multiface 1.5 - 200 (2x100 g))
- 1 Caulking Gun 200/400
- 1 Carding Brush
- 1 Round Brush
- 3 Static Mixers
- 1 Tool Box

MATO BOND Starter Set 400

Starter Set 400	38 078 63	3.7
-----------------	-----------	-----

including:

- 1 Double Cartridge MF-1.5 -400 (2x200 g)
(Multiface 1.5 - 400 (2x200 g))
- 1 Caulking Gun 200/400
- 1 Carding Brush
- 1 Round Brush
- 3 Static Mixers
- 1 Tool Box

Accessories

Caulking Gun 50	38 078 70	0.2
Caulking Gun 200/400	38 078 87	1.4
Tool Box (without image)	38 079 79	1.9
Static Mixer 25/50	38 078 94	0.1
Static Mixer 200/400	38 079 00	0.1
Carding Brush	38 079 17	0.1
Spare belt for Carding Brush	38 079 24	0.1
Belt Grinder	38 051 11	0.2
Belt Grinder Cone	38 079 48	0.1
Rotating Carding Brush ø100 mm x 23 mm with internal thread M14	38 079 31	0.2

Additional accessories and different colors of BOND are available upon request



mato

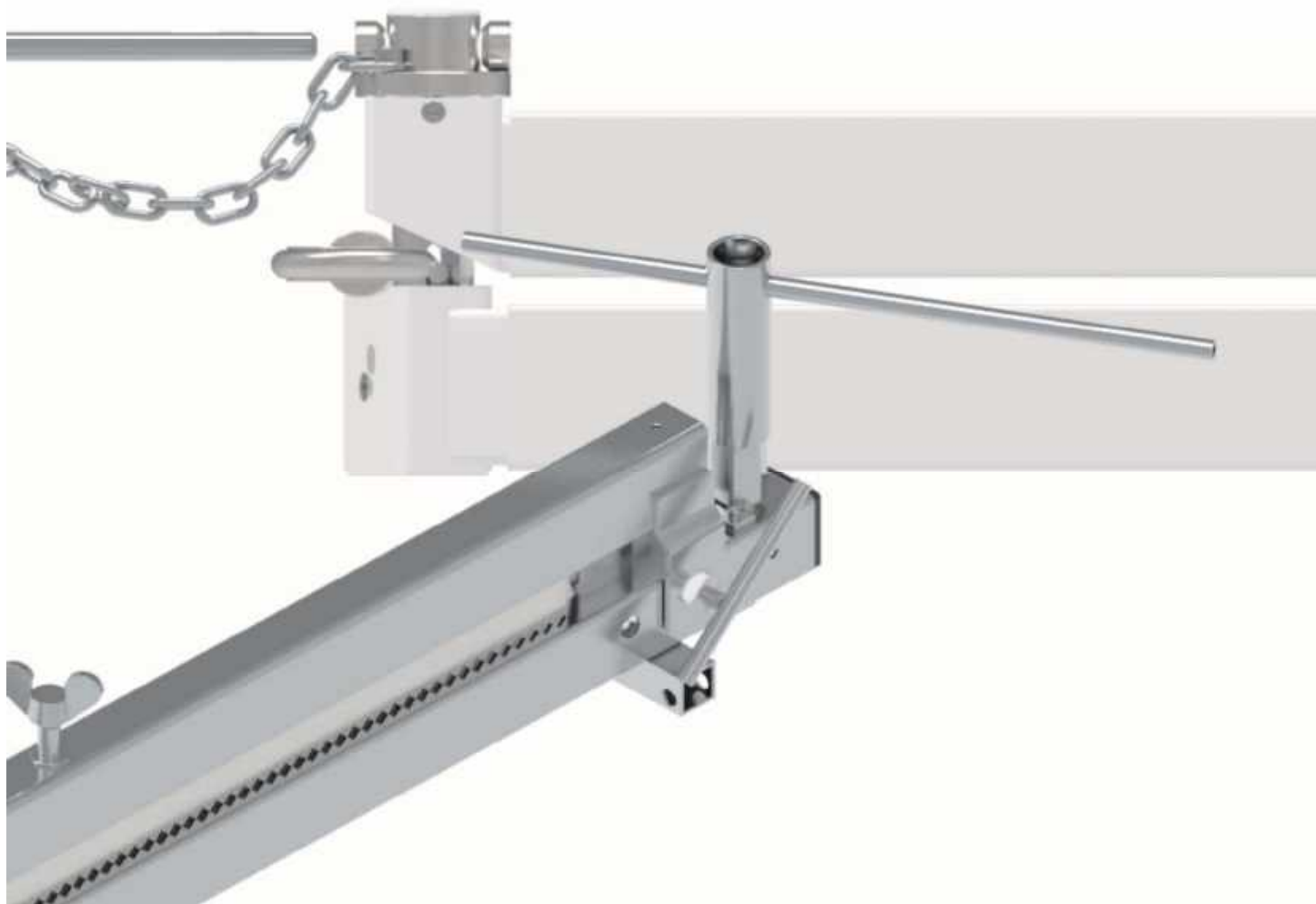

Description Admissible Belt Width Order No. kg

Belt Clamp S - Admissible Working Load 60 kN, Belt Thickness 5 - 35 mm

Safety is MATO's top priority; therefore, our Belt Clamps are subject to high inspection requirements (e.g. 2-times nominal load). They are load handling devices, they tension and relieve the conveyor belt, and they are applied in pairs. While in service, they form a secure working area with a relieved conveyor belt. They come in 2 nominal strengths **30 kN and 60 kN**. Further sizes are available upon request PU = 2 pieces (One for each belt end)

Belt Clamp S 60kN (Nominal Width 1000 mm)	920 to 1000	41 126 13 92	116.8
Belt Clamp S 60kN (Nominal Width: 1200 mm)	1140 to 1220	41 126 13 94	128.0
Belt Clamp S 60kN (Nominal Width: 1400 mm)	1320 to 1400	41 126 13 96	137.2



Belt Clamp S - Admissible Working Load 30 kN, Belt Thickness 5 - 30 mm

Belt Clamp S 30kN (Nominal Width: 1000 mm)	920 to 1000	41 125 12 04	63.0
Belt Clamp S 30kN (Nominal Width: 1200 mm)	1140 to 1220	41 125 12 15	73.6
Belt Clamp S 30kN (Nominal Width: 1400 mm)	1320 to 1400	41 125 12 31	79.8



Other Accessories

Belt Width Order No. kg

T-Square for all Belt Thicknesses

T-Square (90°) with Blade Guide - concipated for cutting to square conveyor belts with a knife.

up to 1000 mm	41 122 00 00	4.4
up to 1200 mm	41 122 00 10	5.0
up to 1400 mm	41 122 00 20	5.6
up to 1600 mm	41 122 00 30	7.0
up to 1800 mm	41 122 00 40	7.6



Mark and Cut

Belt Marker BT-1 Belt Marker permanently marks conveyor belts. Marking depth approx. 0,8 mm, width approx. 2,0 mm	38 559 70	0.1
---	-----------	-----



Belt Gripper	46 800 00 05	0.80
---------------------	--------------	------



Description Order No. kg

Rotary Belt Cutter T - without gear for Belt Thicknesses up to 15 mm

For a perfect symmetric cut in textile conveyor belts up to 15 mm thickness. Usable from both sides. Drive Handle* is removable. T-square can be dismantled

up to 900 mm	41 000 10 61	18.7
up to 1200 mm	41 000 10 63	22.4
up to 1500 mm	41 000 10 65	26.1
up to 1800 mm	41 000 10 72	29.8

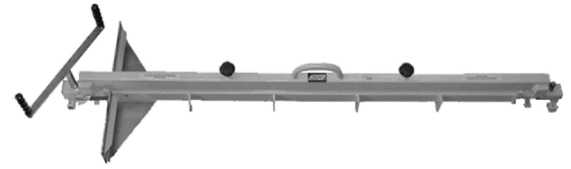

Rotary Belt Cutter TMG - with gear for Belt Thicknesses up to 25 mm

For a perfect symmetric cut in textile conveyor belts up to 25 mm thickness. Usable from both sides. It comes with a gear for lesser effort. Drive Handle* is removable.

up to 900 mm	41 000 13 28	22.4
up to 1200 mm	41 000 13 32	26.1
up to 1500 mm	41 000 13 60	29.8
up to 1800 mm	41 000 13 72	33.5



HD Belt Cutter - Belt Thickness 15 - 35 mm

For a perfect symmetric cut in textile conveyor belts from 15 - 35 mm thickness. Usable from both sides. designed especially for high tensile belts.

up to 1200 mm	42 123 00 37	45.1
up to 1400 mm	42 123 00 38	47.0
up to 1600 mm	42 123 00 32	50.9
up to 1800 mm	42 123 01 00	54.8
up to 2000 mm	42 123 01 06	62.5



Spare Blades for Belt Cutter

Spare Blade TMG + HD	46 000 10 67	0.1
Spare Blade T	41 000 20 00	0.1



Spare Blade for Belt Cutter ECO + T



Spare Blade for Belt Cutter TMG + HD

* included in delivery

Order Number	S.	Order Number	S.	Order Number	S.	Order Number	S.	Order Number	S.
42 133 19 17	14	42 160 20 02	8	46 100 63 39	34				
42 133 19 85	14	42 160 20 03	8	46 100 63 40	34				
42 134 06 35	28	42 160 20 04	8	46 100 63 41	34				
42 134 07 35	28	42 160 20 11	4	46 100 63 42	34				
42 134 07 85	28	42 160 20 12	4	46 100 63 43	34				
42 134 08 00	15	42 160 20 13	4	46 100 63 44	34				
42 134 08 85	28	42 701 20 00	35	46 100 63 45	34				
42 134 09 00	15	42 701 20 10	35	46 100 63 46	34				
42 134 09 85	28	42 701 20 20	35	46 100 63 47	34				
42 134 10 00	15	42 701 20 30	35	46 100 63 48	34				
42 134 10 35	28	42 701 20 40	35	46 100 66 05	33				
42 134 10 50	15	42 701 20 50	35	46 100 66 10	33				
42 134 11 85	28	42 701 20 60	35	46 100 66 15	33				
42 134 12 00	15	42 701 20 70	35	46 100 67 20	33				
42 134 13 35	28	43 121 34 36	11	46 100 67 21	33				
42 134 13 50	15	43 121 34 40	11	46 100 67 22	33				
42 134 13 85	28	43 121 34 56	11	46 100 67 23	33				
42 134 14 00	15	43 122 10 04	11	46 100 67 24	33				
42 134 15 85	28	43 122 10 05	11	46 100 67 25	33				
42 134 16 00	15	43 122 10 10	11	46 100 67 26	33				
42 134 18 00	15	43 122 10 14	11	46 100 67 27	33				
42 134 20 00	15	43 122 10 15	11	46 100 67 28	33				
42 135 06 35	28	43 122 10 20	11	46 100 67 29	33				
42 135 07 35	28	43 123 00 03	12	46 100 67 30	33				
42 135 07 85	28	43 333 02 00	25	46 100 67 31	33				
42 135 08 85	28	43 333 03 00	25	46 100 67 32	33				
42 135 09 85	28	44 130 16 03	24	46 100 67 33	33				
42 135 10 35	28	44 130 16 07	24	46 100 67 34	33				
42 135 11 85	28	46 000 00 78	26	46 100 67 36	34				
42 135 13 35	28	46 000 09 78	32	46 100 67 37	34				
42 135 13 85	28	46 000 09 79	32	46 100 67 38	34				
42 135 15 85	28	46 000 09 82	32	46 100 67 39	34				
42 136 07 35	28	46 000 09 83	32	46 100 67 40	34				
42 136 07 85	28	46 000 09 84	32	46 100 67 41	34				
42 136 08 85	28	46 000 10 00	25	46 100 67 42	33				
42 136 09 85	28	46 000 10 37	26	46 333 02 00	26				
42 136 10 35	28	46 000 10 39	26	46 333 03 00	26				
42 136 11 85	28	46 000 10 41	26	46 800 00 05	38				
42 136 13 35	28	46 000 10 45	26						
42 136 13 85	28	46 000 10 47	26						
42 136 15 85	28	46 000 10 49	26						
42 139 08 85	14	46 000 10 50	25						
42 139 09 00	15	46 000 10 52	26						
42 139 10 35	14	46 000 10 53	26						
42 139 10 50	15	46 000 10 54	26						
42 139 13 35	14	46 000 10 56	26						
42 139 13 50	15	46 000 10 67	39						
42 139 16 00	15	46 000 10 70	25						
42 139 20 17	14	46 000 11 72	31						
42 139 20 18	14	46 000 11 73	32						
42 139 20 19	14	46 000 13 54	31						
42 139 20 20	14	46 100 10 60	24						
42 139 20 21	15	46 100 60 10	31						
42 139 20 22	15	46 100 60 30	31						
42 139 20 23	15	46 100 60 40	31						
42 139 20 24	15	46 100 60 53	31						
42 139 20 25	14	46 100 60 54	31						
42 139 20 26	15	46 100 60 60	31						
42 139 40 35	28	46 100 61 25	34						
42 139 41 85	28	46 100 62 60	34						
42 139 43 35	28	46 100 62 61	34						
42 139 43 85	28	46 100 62 62	34						
42 139 45 85	28	46 100 63 00	34						
42 139 47 85	28	46 100 63 01	34						
42 139 48 85	28	46 100 63 02	34						
42 139 49 85	28	46 100 63 04	34						
42 139 50 35	28	46 100 63 05	34						
42 139 51 85	28	46 100 63 07	34						
42 139 53 35	28	46 100 63 08	34						
42 139 53 85	28	46 100 63 09	34						
42 139 55 85	28	46 100 63 11	34						
42 139 57 85	28	46 100 63 12	34						
42 139 58 85	28	46 100 63 13	34						
42 139 59 85	28	46 100 63 21	34						
42 140 06 35	14	46 100 63 22	34						
42 140 07 35	14	46 100 63 23	34						
42 140 08 85	14	46 100 63 25	34						
42 140 10 35	14	46 100 63 26	34						
42 140 13 35	14	46 100 63 28	34						
42 140 15 85	14	46 100 63 29	34						
42 160 10 02	12	46 100 63 30	34						
42 160 10 03	12	46 100 63 32	34						
42 160 10 04	12	46 100 63 33	34						
42 160 10 20	12	46 100 63 35	34						
42 160 20 00	8	46 100 63 37	34						

I. Quotation

The documentation pertaining to the quotation such as illustrations, drawings, details of weights and dimensions are only approximately authoritative where they are not expressly designated as binding. The supplier retains the right to ownership and Copyright of all cost estimates, drawings and other papers. These must not be made accessible to third parties. The supplier has an obligation not to make accessible to third parties any plans designated as confidential by the purchaser, without the latter's approval.

II. Scope of the delivery

The written order confirmation from the supplier is definitive for the scope of the delivery. In the case of a quotation from the supplier with a time commitment and timely acceptance, the quotation is definitive, where there is no confirmation of the Order in good time. Supplementary agreements and changes require the written confirmation of the supplier.

III. Price and payment

1. In the absence of any special agreements the prices are ex works, including loading at the factory, but excluding packing. VAT at the applicable statutory rate must be added to the prices.
2. In the absence of any special agreement payment is to be made in cash with no deductions and free of charge at the supplier's point of payment within 30 days after dispatch.
We grant a discount of 2% if the payment is carried out within 14 days after dispatch.
3. The withholding of payments or the offsetting of any counter claims by the purchaser which are disputed by supplier are not permitted.
4. For orders of less than EUR 50,- nett invoice value we charge a handling charge of additional EUR 15,- for each order.
5. In case of disproportional increases of costs such as labour or material costs we preserve the right for price adaptations even within the period of validity of this price list.

IV. Delivery time

1. The delivery time begins with the sending of the order confirmation but not before the purchaser furnishes the documents, approvals, clearances to be provided and also the arrival of the agreed down payment.
2. The delivery times will be extended commensurately in the event of actions which form part of labour disputes, especially strikes and lockouts and also in the event of any unforeseen impediments which are outside the control of the supplier where such impediments can be shown to have a considerable influence of the manufacture or shipment of the object being supplied. This also applies when these circumstances occur at sub-suppliers. The circumstances described are also not to be blamed by the supplier when they arise during an already existing delay. In important cases the supplier will notify the purchaser of the beginning and end of such impediments as soon as possible.
3. The delivery times has been adhered to if by the time it expires the object being supplied has left the factory or its readiness for despatch has been notified.
4. When damage is suffered by the purchaser as a result of delay which has occurred due to the supplier, the purchaser is entitled to request compensation for the delay, to the exclusion of further claims. For each full week of lateness this will amount to 1/2 of 1%, but at the most 5% of the value of that part of the total delivery which as a result of the delay cannot be utilised in good time or in accordance with the contract.
5. If despatch is delayed at the wish of the purchaser he will be charged for the cost of storage beginning one month after indication of readiness for despatch, for storage at the supplier's factory however at least 1/2 of 1% of the invoiced amount for each month. The supplier however is entitled after setting a suitable period and its fruitless expiry to make other use of the object being supplied and to supply the purchaser over a suitable extended period.
6. Adherence to the delivery period assumes the purchaser meets his contractual obligations.

V. Transfer of risk and acceptance

1. The risk is transferred to the purchaser at the latest upon despatch of the supplied parts, i.e. even if partial deliveries are made or the supplier has taken on further services such as the costs of despatch or transport and setting up. At the request of the purchaser, and at his expense, the shipment can be insured against theft, breakage, transport, fire and water damage and other insurable risks.
2. If the despatch is delayed as a result of circumstances which are the fault of the purchaser, then the risk is transferred to the purchaser from the day of readiness for despatch; the supplier is however under an obligation, at the wish and expense of the purchaser, to effect insurance which the latter request.
3. Objects supplied, even if they exhibit insignificant defects, are to be accepted by the purchaser regardless of the rights under section VII.
4. Partial deliveries are permissible.

VI. Right of ownership

1. The supplier retains the right of ownership to objects supplied until the arrival of all payments under the contract to supply.
2. The supplier is entitled to insure the object supplied against theft, breakage, transport, fire and water damage and other damage at the purchaser's expense when the purchaser has not shown that he has taken out hat insurance himself.

For defects in the delivery, which includes the absence of the properties explicitly promised, the supplier has the following obligations, to the exclusion of further claims regardless of section IX, 4.

VII. Liability for defects in the delivery

1. All parts which within six month of commissioning prove to be unusable or whose usability is significantly impaired as a result of a state of affairs which was present before the transfer of risk, particularly due to faulty construction, poor material or bad workmanship will be repaired or supplied new at the choice of the supplier, as he judges best.

The discovery of such defects is to be reported to the supplier in writing without delay. Replaced parts become the property of the supplier. If despatch, set up or commissioning is delayed, without blame being attached to the supplier then this liability expires at the latest 12 month after the transfer of risk. For essential third party products the supplier's liability is limited to the transfer of the entitlement to liability which exists vis a vis the sup-supplier of the third party product.

2. The right of the purchaser to assert claims due to defects expires in all cases in 6 months from the time of the punctually made complaint, or upon the expiry of the warranty period.
3. No warranty is taken on for damage which occurs due to the following reasons; unsuitable or improper use, incorrect fitting or incorrect repair by the purchaser or by a third party, natural wear and tear, incorrect or negligent treatment, unsuitable operating materials, replacement materials defective construction work, unsuitable construction site, chemical, electro-chemical or electrical effects for which the blame cannot be attributed to the supplier.
4. To allow the repairs and the supply of replacements to be carried out, which appear necessary in the best judgment of the supplier the purchaser, after agreement with the supplier, must provide the necessary time and opportunity otherwise the supplier is released from his obligation for the defect. Only in urgent cases where operational safety is a risk or to avoid disproportionately large damage, whereupon the supplier must be made aware immediately, or if the supplier is delayed in eliminating the defect, the purchaser has the right to eliminate the defect himself or have it eliminated by a third party and to demand reimbursement of the necessary costs from the supplier.
5. Of the direct costs incurred by the repairs of the supply of replacements the supplier will - insofar as the complaint is shown to be justified- bear the cost of the replacement items including the despatch, plus the reasonable costs for the removal and fitting and furthermore, where this can be rightly requested depending on the situation of the individual case, any necessary costs for providing his mechanics and assistants. The purchaser generally bears all other cost.

6. The warranty period on the replacement items and the repair is three months, but this will run until the time of the expiry of the original warranty period for the object supplied. If repairs are necessary the period of liability for the object supplied will be extended by the length of the interruption in operation caused by this.
7. Any modifications or repair work carried out on the part of the purchaser or a third party either inexpertly or without the prior approval of the supplier will cancel the liability for the consequences such actions.
8. Further claims by the purchaser, especially claims for damage which did not occur on the supplied object itself are excluded. The exclusion of liability does not apply if the owner or leading the owner or leading employee, the supplier is only liable for sensibly foreseeable damage typical of the contract. The exclusion of liability also does not apply in cases where in accordance with the product liability law liability is accepted for damage to persons or property on privately used objects, where faults exist on the object supplied. It also does not apply when properties.

VIII. Liability for associated obligation

When, through the fault of the supplier, the object supplied cannot be used by the purchaser in accordance with the contract as a result of omitted or incorrect implementation of suggestions or advice which occurred before or after conclusion of the contract and also other obligations related to the contract, especially instructions for the operation and maintenance of the object supplied then the rulings in Section VII and IX apply appropriately, to the exclusion of further claims by the purchaser.

IX. The rights of the purchaser to withdrawal, variation and other liability of the supplier

1. The purchaser can also withdraw from the contract if the whole provision of supplies and/or services becomes completely impossible for the supplier before the transfer of risk. The same applies in the event of the supplier's inability to deliver. The purchaser can also withdraw from the contract, for an order of objects of the same type, the implementation of a part of the delivery becomes impossible with respect to quantity or he has a justified interest in refusing a partial delivery, if this is not the case the purchaser can reduce the counter payment to suit.
2. If a delivery delay exists as defined under Section IV of the Conditions of Supply and if the purchaser grants the supplier who is in arrears with the delivery a suitable extension period with an explicit declaration that after the expiry of this period he will refuse to accept the goods and/or services, and if this extended deadline is not met, then the purchaser is entitled to withdraw.
3. If the impossibility occurs during the delay in acceptance or due to the fault of the purchaser then the purchaser remains obliged to make the counter payment.
4. The purchaser also has the right to cancellation of the contract if the supplier, through his own fault, allows a suitable extension period granted to him for repairs of the supply of replacements with regard to a defect, as defined in the conditions of supply and attributable to him, to expire fruitlessly. The right of the purchaser to cancellation of the contract also exists in other cases of failure of the supplier to repair or supply a replacement.
5. Further claims by the purchaser are excluded, especially to termination or reduction and also to compensation for damages of any kind i.e. also for any damages which did not occur on the supplied object itself. This exclusion of liability does not apply if the owner or leading employee have acted with intent or gross negligence and also if there has been blameworthy violation of essential obligations under the contract. In the event of blameworthy violations of essential obligations under the contract, except in cases of intent or gross negligence by the owner or leading employee, the supplier is only liable for sensibly foreseeable damage typical of the contract. The exclusion of liability also does not apply in cases where in accordance with the product liability law liability is accepted for damage to persons or property on privately used objects, where faults exist on the object supplied. It also does not apply when properties are absent which were expressly promised when the promise had the intention of covering the purchaser against damage which did not arise on the supplied object itself.

X. Court of jurisdiction

If the purchaser is a fully qualified merchant, a legal personage in public law or a legally separate property proceedings for all disputes arising from a contractual relationship are to be taken at the court with jurisdiction for the supplier's head office or the branch of the supplier which made the delivery. The supplier is also entitled to take proceedings against the buyer at the court of jurisdiction for his head office.

MATO GmbH & Co. KG
63165 Mühlheim
Germany

More High Quality Products for Belt Maintenance from MATO:

- Belt Lacing <math><750\text{ kN/m}</math>
- Belt Cleaner

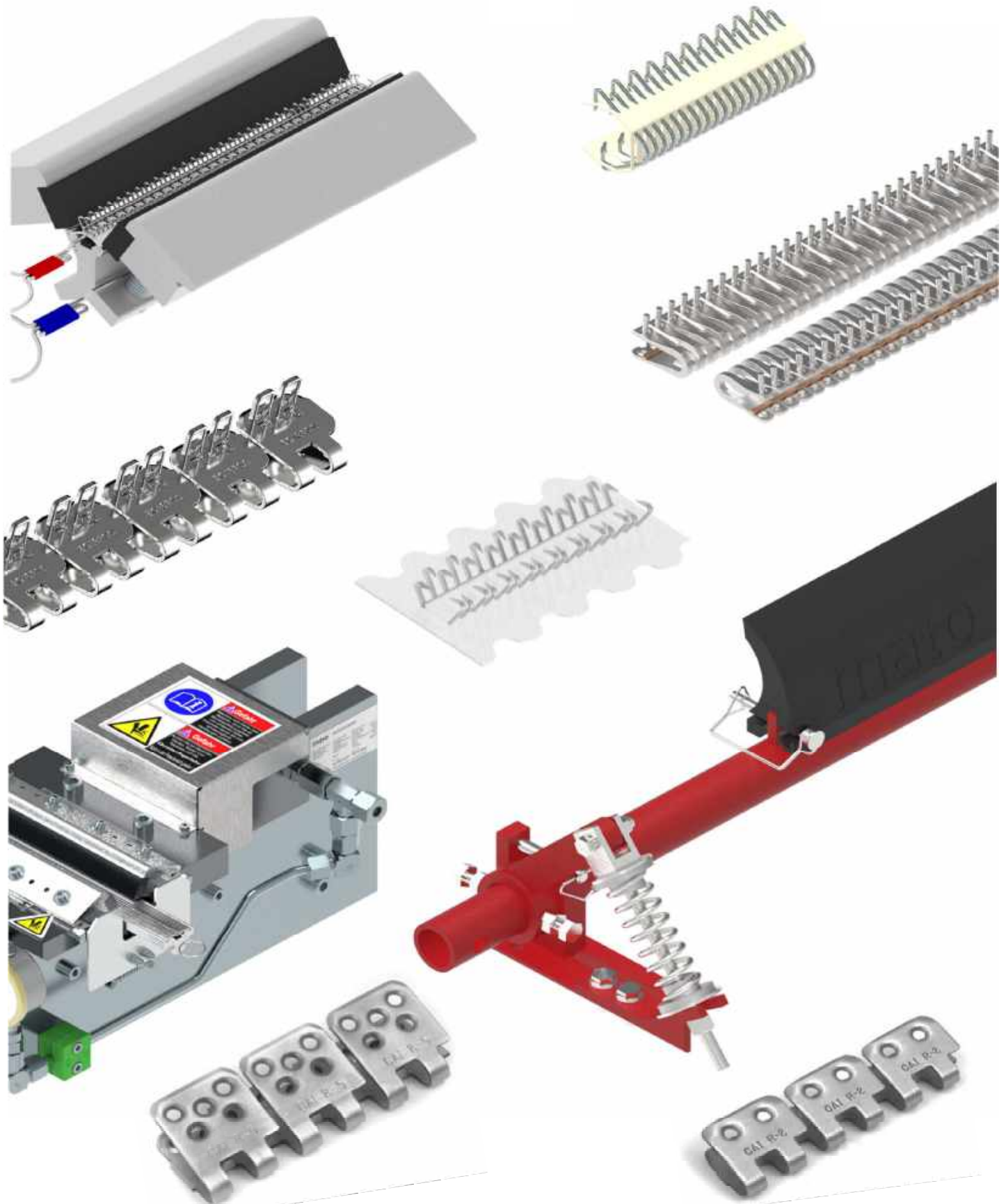

mato

MATO Product Divisions:

Lubrication Equipment - Fluid Handling Products

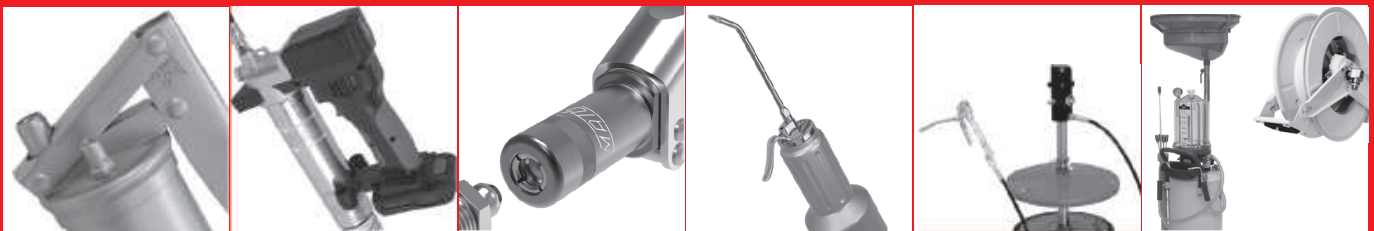

Belt Maintenance Systems - Products for Conveyor Belts

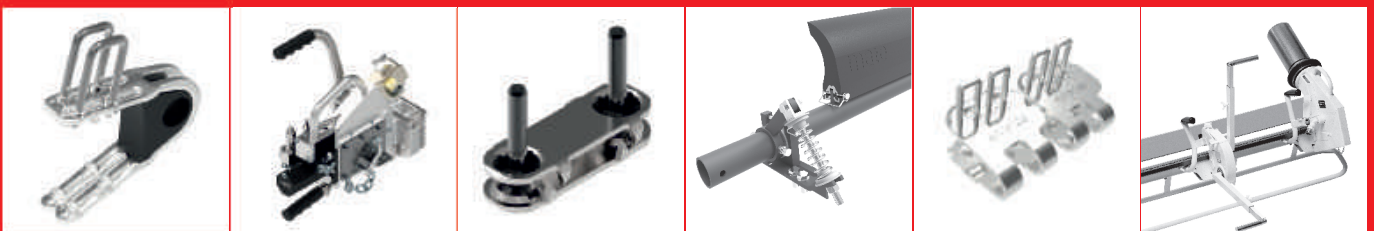

Global expertise in Belt Maintenance Products

mato

Valid from: 01.04.2022



MATO GmbH & Co KG
Benzstr. 16-24
63165 Mühlheim a.M.
Germany
Tel.: +49 (0) 6108 - 906-0
Fax: +49 (0) 6108 - 906-120
www.mato.de
beltlacing@mato.de



MATO Industries Ltd.
Unit 1 Philips Road
Whitebirk Ind. Estate
Blackburn, Lancashire
Bb1 5PG United Kingdom
Tel.: +44 (0) 1254 - 387638
Fax: +44 (0) 1254 - 238023
info@mato.co.uk



MATO Corporation
201 Resource Drive
Beckley, WV 25801
West Virginia USA
Tel.: +1- 304 - 255 1280
Fax: +1- 304 - 255 2501
info@mato-usa.com



MATO Australia Pty Ltd.
39 Bonville Avenue
Thornton, NSW 2322
Australia
Tel.: +61 1300-850 795
Fax: +61 2 4936-1388
maus@mato.com.au



MATO France S.A.R.L.
Zone Artisanale du Grunhof
2 Rue du Grunhof
57890 Porcellette, France
Tel.: +33 -(0) 3 - 87821215
Fax: +33 - (0) 3 - 87297213
mato.france@mato.de



MATO Iberica, S.L.
Pol. Industrial Mora Garay
Calle Marie Curie, parc. 36/38
E-33211 Gijón, Spain
Tel.: +34 (0) 985 - 328900 / 328211
Fax: +34 (0) 985 - 322647
matoiberica@matoiberica.es



MATO Products Pty Ltd.
P.O. Box 224
Kempton Park 1620
28 Forge Road Spartan
South Africa
Tel.: +27 (0) 11-928 4163
Fax: +27 (0) 11-923 6071
matosales@multotec.co.za



MATO Industrial Technology
(Qufu) Co., Ltd.
West End of Changchun Road,
Development Zone of Qufu City
273100 Qufu City, Shandong
China, PRC
Tel: +86-537-4533799
Fax:+86-537-4533299
info@mato.com.cn



MATO Sib
Uliza Telefonnaja 15
Kemerovo
652523 Leninsk-Kusnezkiy
Russian Federation
Tel.: +7 (0) 38456 35166
Fax: +7 (0) 38456 35166
mato-sib@yandex.ru



MATO Sales Rep.Latinoamérica
Cra.41a N°22 Sur 87
Envigado,
Colombia
Tel.: +57 317 3620751
csouto@mato-latam.com



MATO Suisse AG
Industriestrasse 53
CH-6034 Inwil
Switzerland
Tel.: +41 (0) 41 - 4490990
Fax: +41 (0) 41 - 4490992
info@mato.ch



MATO Uglemechanisatija
Str. Krymskogo 27A
03142 Kiew
Ukraine
Tel.: +38 (0) 504759258
ygm1@mail.ru



MATO Kasachstan
Erzhanov Street 18
100009 Karaganda
Republic Kasachstan
Tel.: +7- (0) 7 212 910 063
Fax: +7- (0) 7 212 910 063
office@mato.kz



ISO 9001

Q
mato